

ZAMÓWIENIA

tel./fax 42 656 10 51
tel. 42 656 30 20
mail info@avi.net.pl

SPRZEDAŻ:

Łódź, ul. Brzezińska 16

Electrical Heating Cables 2012/13

N-HEAT® COLLECTION

Electrical Heating Cables 2012/13

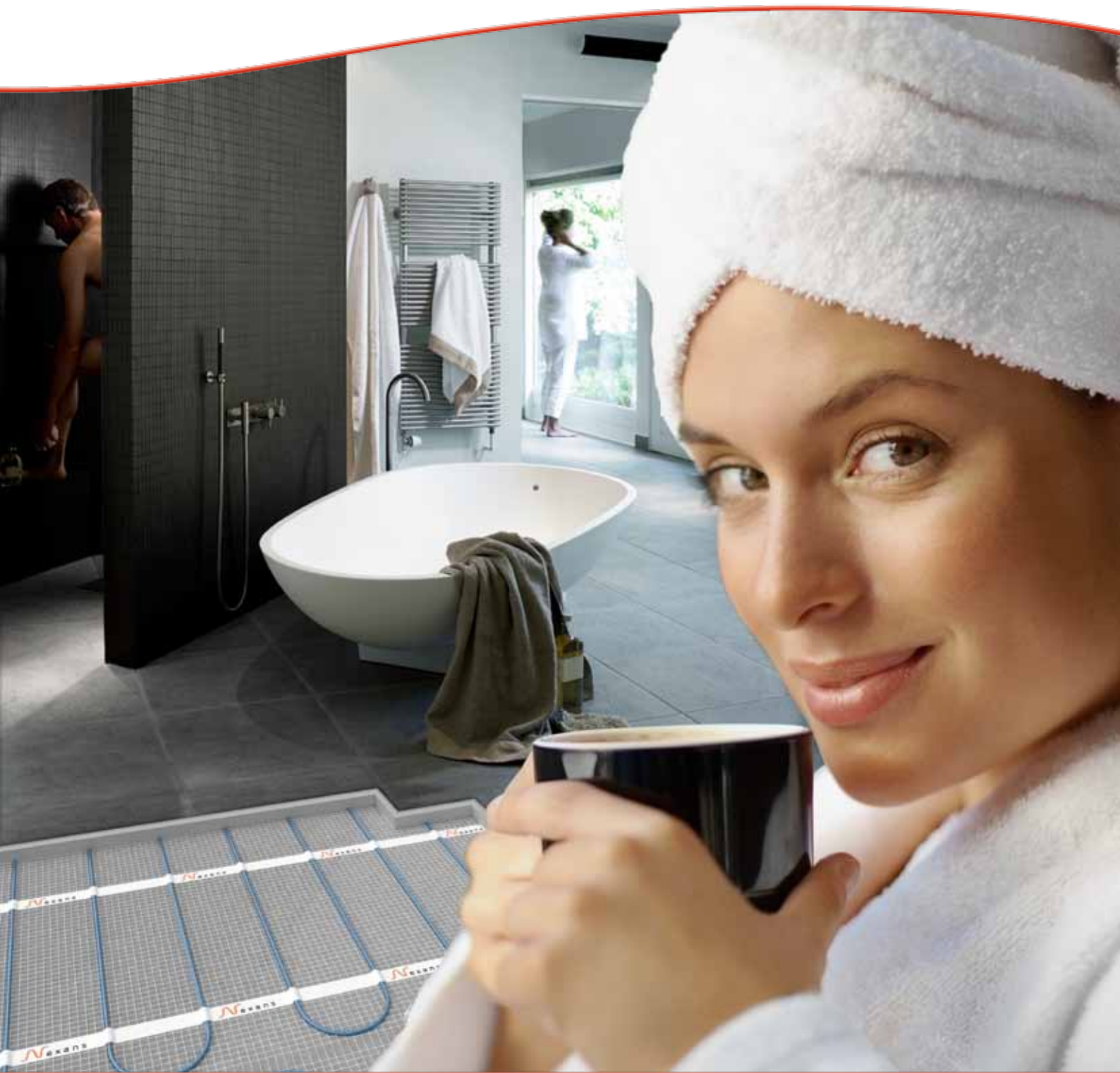

 **Nexans**
www.nexans.com/nheat

Heating cables from Nexans

Heating cables from Nexans have always been regarded as high quality products with focus on easy installation, reliability and safety.



Overview

All products are designed and tested in accordance with international standards, such as IEC and CENELEC standards, and meet the requirements of the European low voltage directive. The production is approved in accordance with the quality standard ISO 9001 and the environmental policy standard ISO 14001. Nexans offers a 20 year warranty on its series resistance heating cable products, and a 10 year warranty on its self limiting heating cable products. This handbook gives an overview of common applications for electrical heating cables and information about the products of Nexans Norway. The products may be subject to national testing and approvals. This handbook contains general recommendations only and it is not intended for any specific country. It contains no national regulations. When using the manual, national regulations and installation requirements must be followed.

Quality

Heating cables from Nexans meet the highest quality standards and are certified by local electrical appliance certifying organizations in all major markets. Our series resistance heating cables come with a 20 year warranty given that they are installed according to our instructions and connected by a qualified electrician.

Innovation

Nexans heating cables are a Norwegian product and invention. We have been producing heating cables for 90 years. Over the years we have continued developing our products to meet changing demands and to introduce better solutions. One example is our unique hidden splice which provides a seamless integration between the hot and the cold part of the cable. Another is the advanced screen of our MILLIMAT cable, and our secure end seals which protect against moisture entering the cable.

Product information

Our Electrical Heating Cables Handbook is designed to give advice and information about heating cables in general and our goal is to provide a handy source of information to the end user, electricians/installers and consultants.

In this handbook you will find information about underfloor comfort heating and many other applications for heating cables including snow melting in driveways and frost protection of pipes. Whether you choose our traditional cables or one of our thin mat products, you are making the right choice by choosing Nexans for your heating cable solution.

You can also advise customers to go to our heating home page at www.nexans.com/nheat for more general information about heating cables and their applications.

Nexans Norway AS reserves the right to implement product changes without notice, as our products are being continuously developed.



Index

Part 1

General information

- 07** Comfort heating in buildings
- 08** Heat loss and load demand
- 09** Project planning and calculations
- 10** Selection of thermostat
- 11** Terms and formulas

Part 2

Applications

- 13** Floor heating in concrete constructions
- 14** Floor heating in bathrooms and wet rooms
- 15** Floor heating in wooden floors
- 16** Floor heating directly below parquet or laminate
- 17** Solutions for renovation projects
- 19** Ice and snow melting installations
- 20** Heating cables in steps
- 21** Frost protection of gutters and roof drains
- 24** Frost protection of pipes and tanks
- 27** Frost protection of freezer room (floors)
- 27** Soil heating
- 28** Drying and hardening of concrete
- 29** Hot water in buildings

Part 3

Product information

Heating cables, series resistance

- 31** N-HEAT® TXLP/2R NORDIC
- 32** N-HEAT® TXLP/1
- 33** N-HEAT® TXLP drum cable
- 34** N-HEAT® MILLICABLE™
- 35** N-HEAT® MILLICLICK™
- 37** N-HEAT® DEFROST SNOW

Heating cable mats

- 38** N-HEAT® MILLIMAT™
- 40** N-HEAT® CABLEMAT
- 41** N-HEAT® SNOWMAT

Heating cables, self-limiting

- 42** N-HEAT® DEFROST PIPE / GUTTER
- 44** N-HEAT® DEFROST WATER and DEFROST WATER KIT
- 45** N-HEAT® WARM WATER PIPE

Thermostats

- 47** N-HEAT® MILLITEMP™ thermostat
- 48** N-HEAT® N-COMFORT thermostat program
- 49** N-HEAT® N-ECO™ thermostat

Accessories

- 50** Accessories for N-HEAT® heating cables
- 51** Accessories for self-limiting heating cables

Part 4

Appendix

- 53** Areas of use for Nexans Heating Cables
- 54** Selection table TXLP/2R 10 W/m
- 55** Selection table TXLP/2R 17 W/m
- 56** Load diagram 120V
- 57** Load diagram 230V
- 58** Load diagram 400V

Part 1

Comfort heating in buildings



- 07 Comfort heating in buildings
- 08 Heat loss and load demand
- 09 Project planning and calculations
- 10 Selection of thermostat
- 11 Terms and formulas

Comfort heating in buildings

Electricity is used the world over as an energy source for heating homes and is the most common energy source. As the world's supply of oil and gas becomes depleted, many of the world's countries will be searching for renewable and environmentally friendly sources of energy. Wind power, solar power, atomic power, and hydro power are some possible solutions. These energy sources produce electricity and may be the future's only viable option.

Advantages of Electrical Underfloor Heating

Using electricity for heating your home is becoming more and more popular. Once you have made the choice to use electricity to heat your home, your choice of heating appliances is numerous. Underfloor heating is becoming the natural choice for many, for obvious reasons. It is invisible, you free wall space compared to solutions with wall mounted panel heaters, it is odorless, and the temperature is easy to control up and down and thus it saves energy. Even further energy savings can be achieved with a modern thermostat with advanced control functions.

Electrical underfloor heating has many advantages over other forms of underfloor heating. Heating cables are economical and easy to install and incur no yearly maintenance costs. With electrical under floor heating you can easily choose to turn off some rooms during the summer months and leave, for example, just the bathroom floor on, with a low setting. With modern thermostats advanced energy saving functions are available, for example setback temperature for day and night savings.

The heat from underfloor heating is a low temperature radiant heat – which means that the air in the room is warmed up and there will be less difference in temperature from floor to ceiling compared to rooms with wall mounted heating. Heating the air at floorlevel will ensure a comfortable heat distribution throughout the room. Heat will not collect close to the ceiling as is the case with convection heating.



Our product range includes traditional heating cables for installation under ceramic tiles in wet rooms to thin mats for installing under wooden type floors and where height could be a problem. Our mats are becoming increasingly more popular for their quick and easy installation. Our products are suitable for renovation projects as well as new building construction.

Electrical underfloor heating can be used to heat your home completely or in combination with other heating sources. Key advantages are flexibility, advanced control possibilities and easy integration possibilities with other systems.

Underfloor heating systems have a reputation for providing a very comfortable inside living environment. Floor heating is ideal in most types of rooms, for example bathrooms, toilets, hallways, living rooms, kitchens and where children play. The floor is a large surface area normally with low temperature. Producing heat under the floor however will ensure radiant heat from the floor and a favorable heat distribution throughout the room. When you compare wall mounted heating with underfloor heating it's proved that you can have a 2-3 °C lower temperature setting with under floor heating and still achieve the same comfort level. This results in a potential 5-10% energy consumption reduction just by choosing underfloor heating over wall mounted panel heaters.

Heat loss and load demand

Floor heating systems are commonly used as the sole heating source for a room.

In new and properly insulated buildings the transmission losses are normally in the range of 40-80 W/m² (3.5 - 7.5 W/sq. ft) building area. In old or poorly insulated buildings the installations are normally based on an installed load of 80-100 W/m² (7.5 - 9.3 W/sq. ft) building area. A building's load demand is dependent upon the outside temperature, desired inside temperature, and how well the building is insulated. The degree of draft from windows and exits will strongly influence the required load demand.

When necessary a full heat loss calculation should be performed in accordance with local requirements and standards.

The following formula and diagram can help you quickly to calculate an estimate of the load demand for a room.

1. Calculate the total window area in relationship to the total floor area. This gives the x-axis value.
2. Draw a line from the x-axis to meet the temperature difference line which best describes your situation and draw a corresponding line to the y axis to find the recommended W/m² floor area.

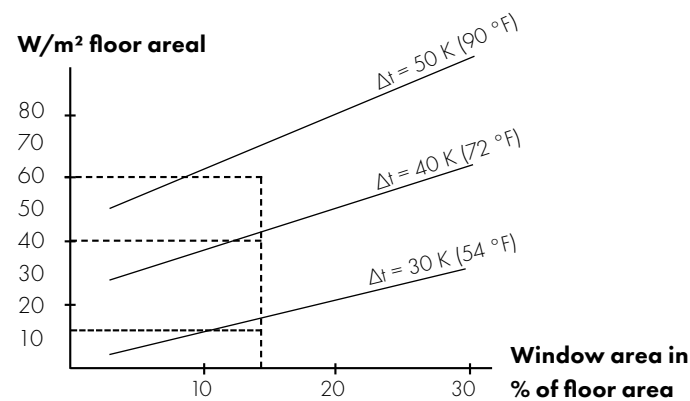

Diagram: Calculation of load demand for buildings.

Assumptions:

Ceiling height is 2.5 meters
The method is not reliable for rooms with open stairways which allow warm air to escape.

Standard heat loss coefficients for:

Windows	U = 2.10 W/m ² K (0.20 W/sq.ft.K)
Outer walls	U = 0.25 W/m ² K (0.23 W/sq.ft.K)
Ceiling	U = 0.23 W/m ² K (0.21 W/sq.ft.K)
Floor	U = 0.30 W/m ² K (0.28 W/sq.ft.K)
Inside temperature	= 20 °C (68 °F)

Project planning and calculations

Correct planning is vital to ensure that a heated floor will provide the best possible comfort, function for many years, and at the same time be energy efficient.

To choose the correct product the following should be considered.

Load demand

The first step is to determine the area load, W/m². For comfort heating applications this can normally be done either by heat loss calculation or by using empirical values (see appendix page 53 in this booklet), which is a quick and reliable method. Heat loss calculations can be a complex matter, and should, if possible, be executed by the architect, planner or the constructor of the building.

Area to be heated

The area load demand is normally regarded as the load demand for the gross area. In rooms with obstacles such as fixed furniture, toilet, bath tub etc, it may be necessary to increase the net area load to compensate for the unheated areas (heating cables shall never be laid under fixed objects).

Selection of heating cable product

The selection of the type of cable shall be based on application type, and construction details such as ground or floor type, load etc. You will find more information in the section describing applications.

Centre spacing

This parameter applies specifically to cable elements and not mats, where the centre spacing is fixed. If the cable is applied with the correct centre spacing, it will cover the entire area. The centre spacing is easily found by dividing net area by cable length.

$$c-c(m) = \frac{\text{Net area [m}^2\text{]}}{\text{Cable length [m]}}$$

NexCalc

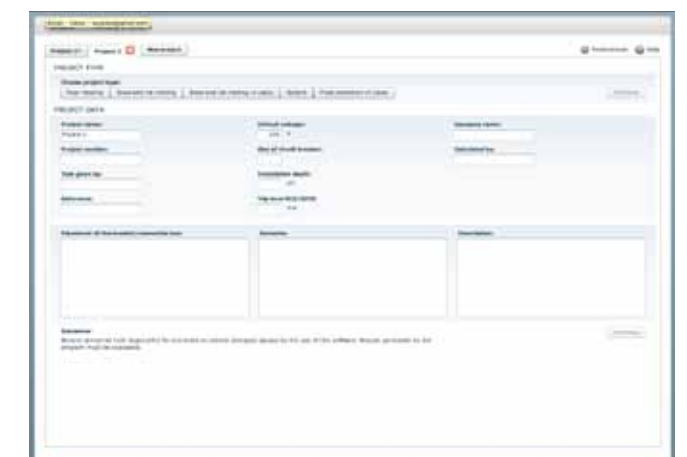

NexCalc

Our Internet solution/program for heating cable calculations is a helpful tool for all project planning where cables and not mats are preferred. Open www.nexans.com/nheat and select calculation, and you are able to use our NexCalc to calculate type of products and amount. The program uses colour coding to give you recommendations and feedback about which calculations are acceptable. Each calculation can easily be printed and used as documentation. There is also a link to the product database where you will find product data sheets for all our products.

Selection of thermostat

Selection guide

Primary task of the heating	Description of purpose	Selection of thermostat type
Comfort heating of floor	Shall give a comfortable heat in floors, e.g. in a bathroom or entrance hall. Also used to secure dry and non-slippery floors in entrances, washing rooms, shops or other public areas.	Electronic thermostat incl. floor sensor.
Floor warming in combination	Shall provide basic heating in the floor, whereas the comfort regulation is done by another heat source.	Thermostat incl. floor sensor.
Floor warming, heating the room	Shall give a comfortable temperature in the entire room.	Thermostat with an integrated or remote room sensor (can be of combined type with a limiting floor sensor).

Selection of limitation sensor

For certain conditions, it might be necessary to use a thermostat that includes a limitation sensor for control of minimum or maximum temperatures.

Min. temperature limitations	Max. temperature limitations
Secures that the floor maintains a comfortable minimum temperature. In the case of direct sunshine heating up a room, the floor heating system may be off so long that the floor temperature will drop. In heavy concrete floor constructions 40 - 80 mm (1.5" - 3.2") the floor heating will react slowly when the heating demand rises.	For installations in wooden floors as well as other applications it might be necessary to limit the maximum temperature of the cable or the floor construction to e.g. 28 °C. (83 °F).

Thermostat control

A thermostat will automatically maintain the desired temperature in a room by turning off and on the heating cables as required. The amount of heating from the heating cables will be influenced by factors such as outdoor temperatures, the heat generated by other electrical appliances, lighting, the sun and even people in the room. These other free heating sources may contribute up to 10-20% of the total heating requirement.

Save up to 25% with setback temperature settings

In weekdays there may only be need for heating during the morning and then again from the late afternoon to the late evening. In offices, the heating is normally needed during the day from Monday till Friday. Up to 15-25% of energy consumption may be saved if the temperature setting is lowered by about 5 °C (41 °F) at night and during the day on weekdays. The setback temperature has its greatest advantage in thin 10 - 20 mm (0.4"-0.8") floor constructions and wooden floors. Heavy constructions 40-60 mm (1.6" - 2.4") take longer to heat up and cool down, thus the time for lowering or raising of the temperature will be longer. This means that a setback temperature should only be used if the setback period is relatively long, e.g. at night.

Installation of thermostat with floor sensor

The correct installation of the sensor is a prerequisite for the correct functioning of the thermostat, as well as for the maintenance of comfort and minimum energy consumption of the installation. The floor sensor must be installed in a section of the floor where there is a high probability that it will not be covered by heavy furniture. The sensor must not be placed close to the heating cable. In order to ensure easy replacement of the sensor in the case of a defect, it should be embedded in a tube in the floor. The tube must be sealed and placed as close as possible to the floor surface – this is the main measuring point. If necessary the sensor cable can be extended. Please check with the thermostat vendor for maximum length.

Installation of thermostat with built-in room sensor

A thermostat with room sensor should be installed approximately 1.6 meter (5') above the floor level. The sensor must not be installed on cold external walls, exposed to draught, direct sunlight or heat from various appliances. If a correct installation is impossible, a remote room sensor should be used.

Please see page 47-49 for more information about Nexans' thermostat programmes.

Technical overview - formulas and terms

Property	Measuring unit and abbreviation	Symbol
Voltage	Volt [V]	U
Current	Ampere [A]	I
Resistance	Ohm [Ω]	R
Power	Watt [W]	P

Ohm's law: $U = R \times I$

Power: $P = U \times I$ (thus $P = R I^2$ and $P = \frac{U^2}{R}$)

For on drum heating cables:

Total resistance [Ω] = Length of cable [m] x specific resistance [$\frac{\Omega}{m}$]

c-c distance [cm] = $\frac{\text{Area [m}^2\text{]} \times 100}{\text{Length of cable [m]}}$

Tables of the most important energy and power units

Energy

kWh	kp m	kcal	Joule = Ws=Nm	hph
1 kWh = -	367 100	860	3 600 000	1,359
1 kp m = 2,724.106	-	2,343.103	9,80665	3,704.106
1 kcal = 1,163.103	426,9	-	4186	1,581.103
1 Joule				
1 WS = 0,2778.103	0,1020	0,2389.103	-	0,3777.103
1 Nm				
1 hph = 0,7355	270 000	632,5	2 648 000	-

Power

kWh	kp m/s	kcal/s	kcal/h	hp
1 kW = -	102,0	0,2389	860	1,359
1 kp m/s = 9,807.103	-	2,343.103	8,434	0,01333
1 kcal/s = 4,186	426,9	-	3600	5,691
1 kcal/h = 1,163.103	0,1186	0,2778.103	-	1,581.103
1 hp = 0,7355	75	0,1757	632,5	-

AWG to square mm Wire Gauge Conversion

American Wire Gauge (AWG)	Diameter (inches)	Diameter (mm)	Cross Sectional Area (mm ²)
0000	0.46	11.68	107.16
000	0.4096	10.40	84.97
00	0.3648	9.27	67.40
0	0.3249	8.25	53.46
1	0.2893	7.35	42.39
2	0.2576	6.54	33.61
3	0.2294	5.83	26.65
4	0.2043	5.19	21.14
5	0.1819	4.62	16.76
6	0.162	4.11	13.29
7	0.1443	3.67	10.55
8	0.1285	3.26	8.36
9	0.1144	2.91	6.63
10	0.1019	2.59	5.26
11	0.0907	2.30	4.17
12	0.0808	2.05	3.31
13	0.072	1.83	2.63
14	0.0641	1.63	2.08
15	0.0571	1.45	1.65
16	0.0508	1.29	1.31
17	0.0453	1.15	1.04
18	0.0403	1.02	0.82
19	0.0359	0.91	0.65
20	0.032	0.81	0.52
21	0.0285	0.72	0.41
22	0.0254	0.65	0.33
23	0.0226	0.57	0.26
24	0.0201	0.51	0.20
25	0.0179	0.45	0.16
26	0.0159	0.40	0.13

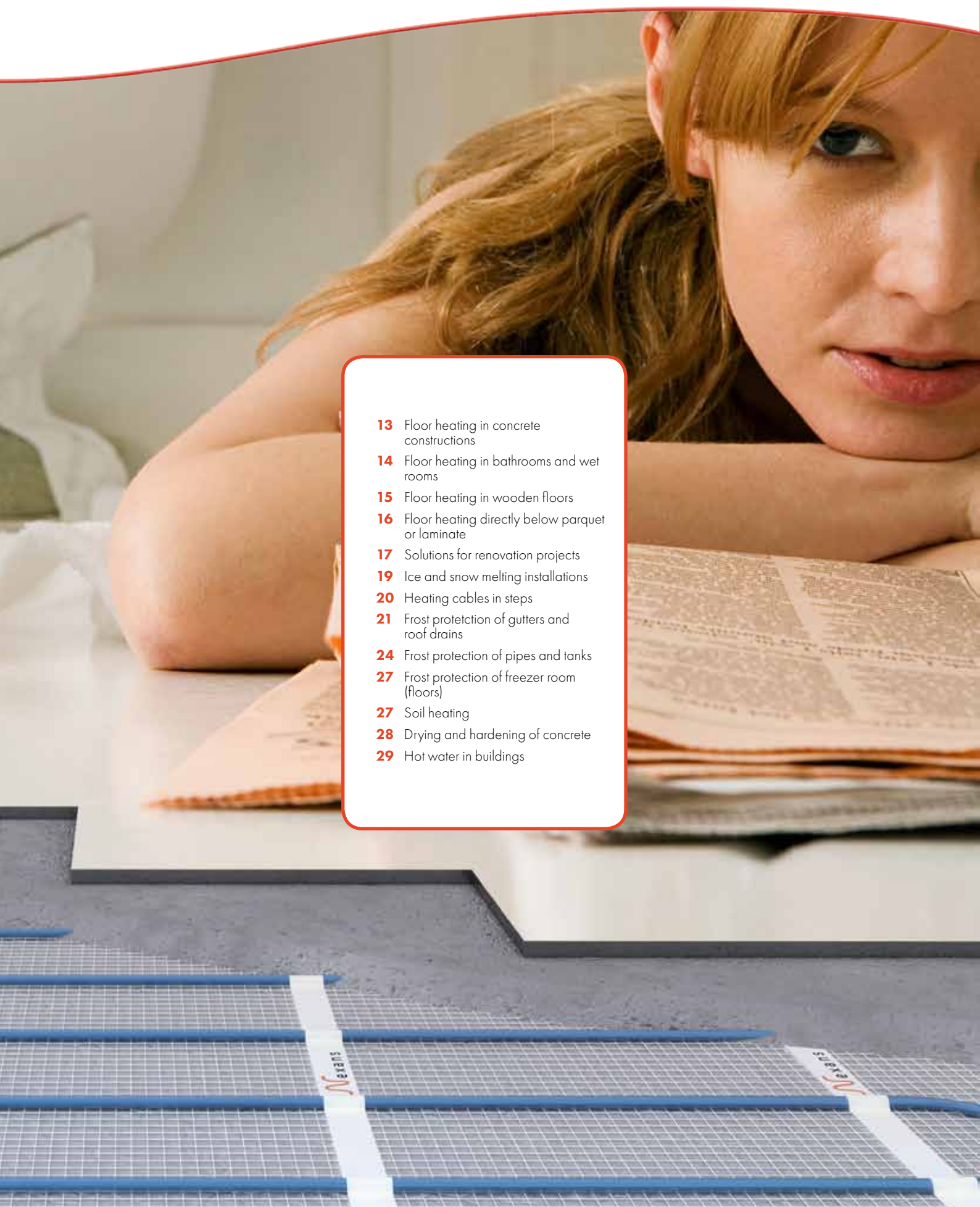

- 13** Floor heating in concrete constructions
- 14** Floor heating in bathrooms and wet rooms
- 15** Floor heating in wooden floors
- 16** Floor heating directly below parquet or laminate
- 17** Solutions for renovation projects
- 19** Ice and snow melting installations
- 20** Heating cables in steps
- 21** Frost protection of gutters and roof drains
- 24** Frost protection of pipes and tanks
- 27** Frost protection of freezer room (floors)
- 27** Soil heating
- 28** Drying and hardening of concrete
- 29** Hot water in buildings

Floor heating in concrete constructions

Area load and C-C distances

For comfort heating in concrete constructions, we recommend the use of MILLIMAT or TXLP heating cable, single or twin conductor elements. To find the correct heating cable element, use this calculation:

$$\begin{aligned} \text{Cable output [W]} &= \\ \text{Gross area [m}^2\text{]} \times \text{[W/m}^2\text{]} & \\ \text{or} & \\ \text{Cable output [W]} &= \\ \text{Gross area [ft}^2\text{]} \times \text{[W/ft}^2\text{]} & \end{aligned}$$

By using the factory made heating cable elements, of e.g. 17 W/m (5.2 W/ft), the calculation of the centre spacing is simplified. The correct centre spacing (c-c distance) describes the distance between the cable loops and can be calculated like this:

$$\begin{aligned} \text{C-C [m]} &= \\ \text{Net area [m}^2\text{]} / \text{Cable length [m]} & \\ \text{or} & \\ \text{C-C [ft]} &= \\ \text{Net area [sq.ft.]} / \text{cable length [ft]} & \end{aligned}$$

Output limitations

In wooden floors/combustible constructions:
Max. 80 W/m² and max. 10 W/m linear output.

In tile/stone/non-combustible constructions:
Max. 150 W/m² and max. linear output 17 W/m.

Direct heating and installation

For comfort heating in buildings direct acting systems normally require 60 - 150 W/m² (5.6 - 13.9 W/sq. ft) depending on the room and building type. These systems require low thermal capacity, and the heating cables are placed as close to the floor surface as permitted by the national authorities and material. Normally this means that the heating cable is placed in the lower part of a max 50 mm (2") thick screed/concrete slab on a high-grade thermal insulation. It is important that the cable is embedded and surrounded completely by the screed/concrete to ensure the best possible heat conductivity to the immediate surroundings of the cable. The cable cannot be installed directly on the thermal insulation, as direct contact with the insulation might cause the cable to overheat during operation. One solution is to put a thin slab just above the insulation and then install the cable on top of this. Another is installing the heating cable (TXLP) on top of a chicken wire or a reinforcement mesh, and in this way creating space between the heating cable and the insulation. Avoid stepping on the cables during the installation.

Pouring of Concrete/Screed

In all kinds of poured floors a good mixture of cement, sand, and water is important. Use the correct amount of components (sand, cement, water) and mix thoroughly using machinery. Apply quickly after mixing. Follow the manual from the vendor. Avoid air pockets and a porous slab by compressing/compacting well. This will ensure the best heat conductivity, which means heat will be transported easily from the cable to the surroundings, and thus result in a floor with quicker response to heat adjustments and protecting the cable from reaching high temperatures. Never put any thermally insulating floor components above the heating cables! The slab with the heating cable must dry and harden by itself, and normally the heating cables cannot be turned on for 6-8 weeks after the concrete/screed has been poured.

Renovation

When renovating, or when space is essential, special thin screed solutions (MILLIMAT) can be used, allowing screed thickness down to 10 - 15 mm (3/8" - 5/8"). Please see separate chapter on renovation.

Storage heating

Storage heating systems normally require an output of 150 - 200 W/m² (13.9 - 18.6 W/sq. ft). These systems require that the heating cables are embedded in a concrete floor construction of high thermal mass. Often an approx. 100 mm (4") concrete slab is laid on top of a high-density insulation, and the cables are installed on top of the slab and covered with an approx. 50 mm (2") screed. With such floors you have the possibility to heat the floor during night and have the power turned off early the next day, then benefit from the heat stored in the slab through the day.



Floor heating in bathrooms and wet rooms

A good choice of area load for bathrooms lies in the range of 120 - 150W/m² (11 - 14 W/sq.ft.).

Controller

Use a thermostat with a floor sensor or a power regulator.

Installation

The heating cable is normally installed on a chicken wire or a reinforcement mesh. Fixing the cable with cable ties can be a good solution, but remember not to tighten the ties too much. Do not tighten a cable tie over the end seal of the cable. The intention is only to keep the cable more or less in place during the pouring of screed/concrete, and over-tightening might damage the cable. If you are installing a twin conductor heating cable with an end seal, remember to put the end seal in a zone where moisture/water most likely won't be present. The chicken wire and/or reinforcement mesh must always be electrically connected to the earth wiring of the installation. If the gully grating/grid is made of metal, this should also be connected to the ground wire.

How to connect ground/earth wire to a chicken wire

- 1 Cut one mesh of the wire.
- 2 Put a shrink tube on the earth wire.
- 3 Separate a small part of the earth wire itself from the insulation and tread it on the cut of the mesh (where two threads meet).
- 4 Fix a crimp terminator on the mesh and the earth wire and apply pressure.
- 5 The shrink tube is pulled over the crimp terminator and moulded around it.
- 6 The earth wire is then connected to the heating cable's earth wire and the main installation's earth wire in the connection box for the switch/thermostat.

If several fields of chicken wire is used these must have an overlap of minimum 150 mm (6").

Floor construction

An optimal installation for bathroom floors where both the positioning of the cables and the floor construction are taken into consideration is shown below with two alternative solutions.

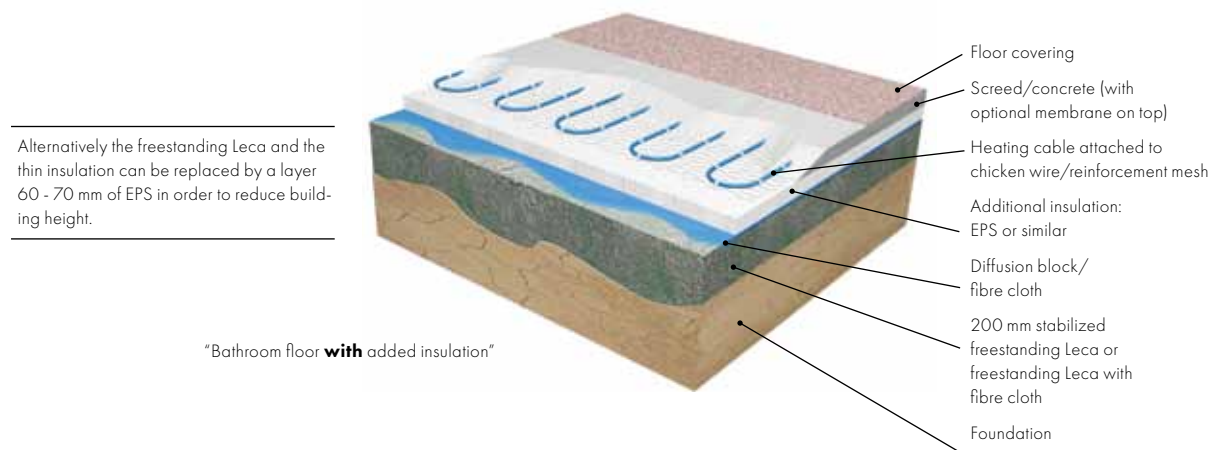

"Bathroom floor **with** added insulation"

The screed/concrete should be laid so that the floor slopes downwards towards the drain, thus all water falling on the floor drains away. In a bathroom it is very important that the screed/concrete layer is uniform and non-porous. See previous page regarding the pouring of concrete.

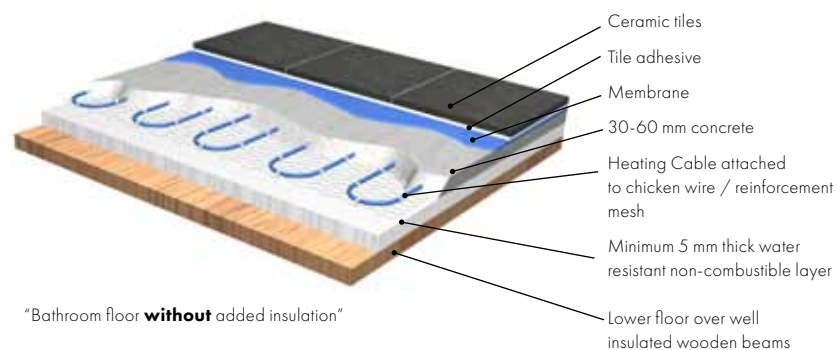

"Bathroom floor **without** added insulation"

Floor heating in wooden floors (between beams)

When using electrical heating cables in wooden floors, cables with 10 W/m or less are usually installed with a maximum of 80 W/m².

For heating requirements of 60 - 70 W/m² (5.6 - 6.5 W/sq.ft) and a cable output of maximum 10 W/m (3W/ft), the centre distance should normally be in the range of 90 - 130 mm. (3.5" - 5.1").

Planning

In order to avoid damaged or creaking floorboards, the following precautions should be taken in rooms where people spend prolonged periods of time:

- Install maximum 60 W/m² (5.6 W/sq.ft).
- Distribute the cables evenly across the entire floor area.
- Protect all material against rain and moisture in the construction period, and make sure that all the materials are dry before the floor covering is laid.

- Use an electronic thermostat with room and floor sensor with limiting function. Ideally the temperature should be limited so that the surface temperature of the floor never exceeds 28 °C. Dependent on floor construction, this corresponds to a higher temperature (normally around 35 °C) in the floor where the floor sensor is installed.

- If possible, floorboards should be placed loosely on top of the heated floor for a few days before they are fastened.
- Avoid laying any thick rugs or wall-to-wall carpets on top of parquet.

Installation

The spaces between the beams should be filled with mineral wool insulation material, creating an air pocket of at least 30 mm (1.2") at the top (see figure). Chicken wire is laid on top of the insulation and the cable is fixed every 350 mm (14"). To attach the cable cut a mask and twist it over the cable. The heating cables are to be laid parallel to the beams. The distance from the cable to combustible material must be at least 10 mm.

When crossing the supporting

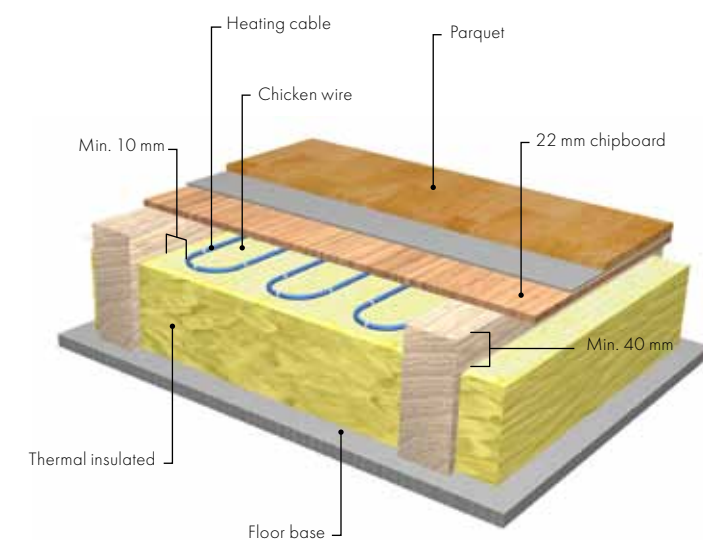

Layer of wooden beams with heating cables

beams, a 10x10 mm slot must be scored, through which the cable will run. The slots must be scored in a way that the supporting function of the beam is not significantly reduced and with min. 50 mm distance between the slots. If the cables can be laid prior to the battening of joists, slots will not be necessary. In so-called platform floors, in which the beams are shut off at an early stage to form a working platform, you are recommended not to install insulation from below since the heating cables may be pushed up towards the floor. This can lead to the cable being enclosed by insulation, reducing the air pocket.



Floor heating directly below wooden parquet or laminate

Nexans floor heating system

MILLICABLE™ and MILLICLICK™

An easy and efficient way to install floor heating. A dry solution without any need for screed or concrete.

The system consists of boards covered with aluminium foil (MILLICLICK) with pre-cut slots for the MILLICABLE.

Remember to choose the correct amount of boards and combination of products. (Please see selection table on page 33).

MILLICABLE is a thin twin conductor heating cable 6 W/m, which can be installed in a traditionally poured floor or together with MILLICLICK boards as a dry-floor heating system. The MILLICABLE is delivered with a factory made end-seal and a splice between the heating element and the cold lead (3.5 m). When installed as a freely laid cable attach the cable to the sub-floor with glue or aluminium tape. C-C distance between cable loops must be calculated in advance. Check cable integrity before pouring screed/concrete.

MILLICABLE in combination with MILLICLICK

MILLICABLE together with

MILLICLICK can be installed directly under wooden floor coverings like parquet, laminate etc. without any use of concrete or levelling compound. The MILLICLICK boards are covered with aluminium foil and have pre-cut slots for the cable which makes the installation very easy to perform. Pre-cut slots have a C-C distance of approx. 10 cm, resulting in an area output of 60 W/m². The boards are placed on a stable and levelled subfloor. MILLICABLE has an outer sheath made of a conductive polymer being in contact with the earth conductor inside the cable. Thus,

by placing the MILLICABLE into the slots the aluminium foil is "connected" to earth potential. No further grounding of the aluminium foil is required.

Install standard parquet underlay between the parquet and the MILLICLICK boards.

MILLICLICK boards shall only be used together with MILLICABLE heating cables.

Solutions for renovation projects

Renovation of existing rooms improves the comfort and value of every home. It is also the perfect opportunity to install electrical floor heating. We have solutions that require minimal elevation of the floor, thus few modifications and adjustments have to be done to the room itself.

Renovation can be done with freely laid cable (TXLP, traditional solution) or with a thin mat solution.

Renovation with TXLP

We recommend using TXLP, twin or single conductor, 10 W/m (3 W/ft) or 17W/m* (5.2 W/ft), elements for this use. Apply the cable (TXLP) to a non-combustible subfloor (minimum thickness 5mm (0.2")) and take into consideration the placement of permanent installations such as water closet, gully, bath tub, etc. Place the end seal away from potentially wet areas of the floor. See picture illustrating the placement of a free laid heating

cable. Note, that the cable is not crossing neither touching itself, this to provide the best possible heat conductivity to the surroundings of the cable. Then the heating cable is embedded in a screed/concrete with low overall height. After drying and hardening the moisture barrier/membrane can be put on top of the screed/concrete before the floor covering is installed.

* In floors with low building height, a linear output of 10 W/m or less is recommended. This to ensure an even heat distribution. If subfloor and/or floor covering are made of combustible materials limit linear output to 10 W/m and area output to 80 W/m².

Please see page 13 for information about pouring.

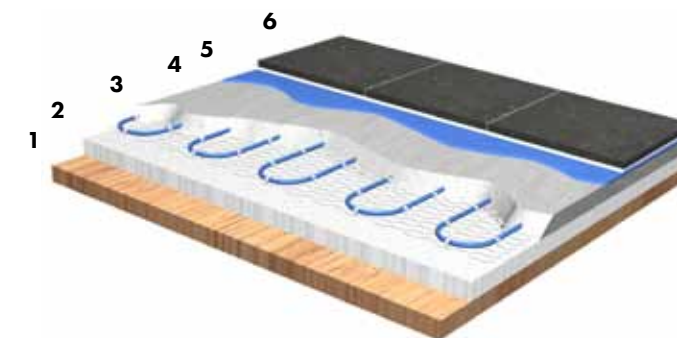
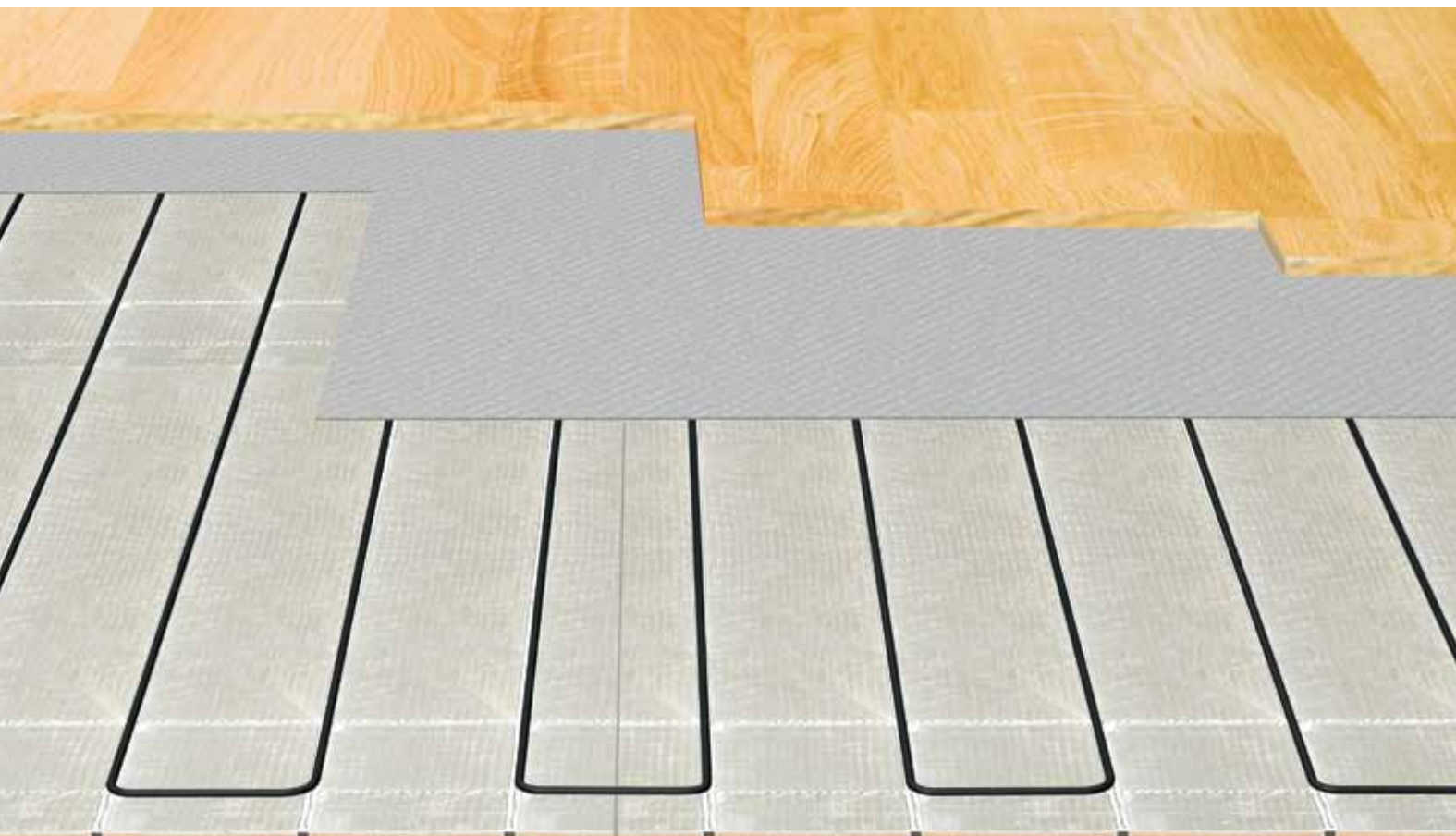

1. Wooden subfloor
2. Non combustibile sub floor (min 5 mm), water resistant in wet rooms
3. Heating cable TXLP glued or attached to chicken wire / reinforcement mesh
4. Thin screed/slab
5. Membrane
6. Adhesive and ceramic tiles

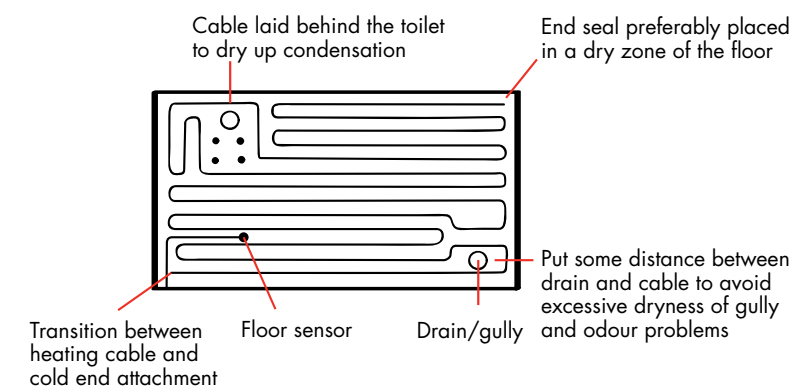

Solution with freely laid cable

Solution with freely laid cable, 30 mm maximum floor elevation – traditional and simple solution using freely laid cable.

Ice and snow melting installations

Renovating with MILLIMAT™

Minimum floor thickness can be important in renovation processes in order to avoid extra work on doors and thresholds. For these projects MILLIMAT is the ideal product.

The heating mat consists of a thin twin conductor heating cable unit attached to an adhesive flexible glass fibre net. The thin heating cable unit is delivered with a 2.5 m cold lead. Total thickness of the mat incl. cable is 4.5 mm (0.18"). The width is 50 cm.

The MILLIMAT can easily be cut and adjusted to adapt the shape of the room. It can be installed directly into the tile glue or embedded in the concrete/screed below the tiles and the tile glue. If installed directly into tile adhesive, be careful not to damage the heating cable when installing tiles.

The 100 W/m² (9.3 W/sq.ft.) mat is recommended for living rooms, hallways, kitchens and rooms alike. The mat can be installed on any type of sub floor, levelled and stable. The 100 W/m² mat may also be used under parquet or other wooden floor coverings, with the recommended use of a thermostat with a temperature limiting function.

The 150 W/m² (13.9 W/sq.ft.) mat is recommended for bath-

rooms, toilets, laundry rooms and other areas requiring high output. The mat must be installed on a non-combustible sub floor, levelled and stable.

A floor in which heating has been installed during renovation is usually very quick and easy to regulate, because the heating mat is located near the top of the floor construction, resulting in low energy consumption.

Please see picture illustrating a basic solution of a MILLIMAT floor.

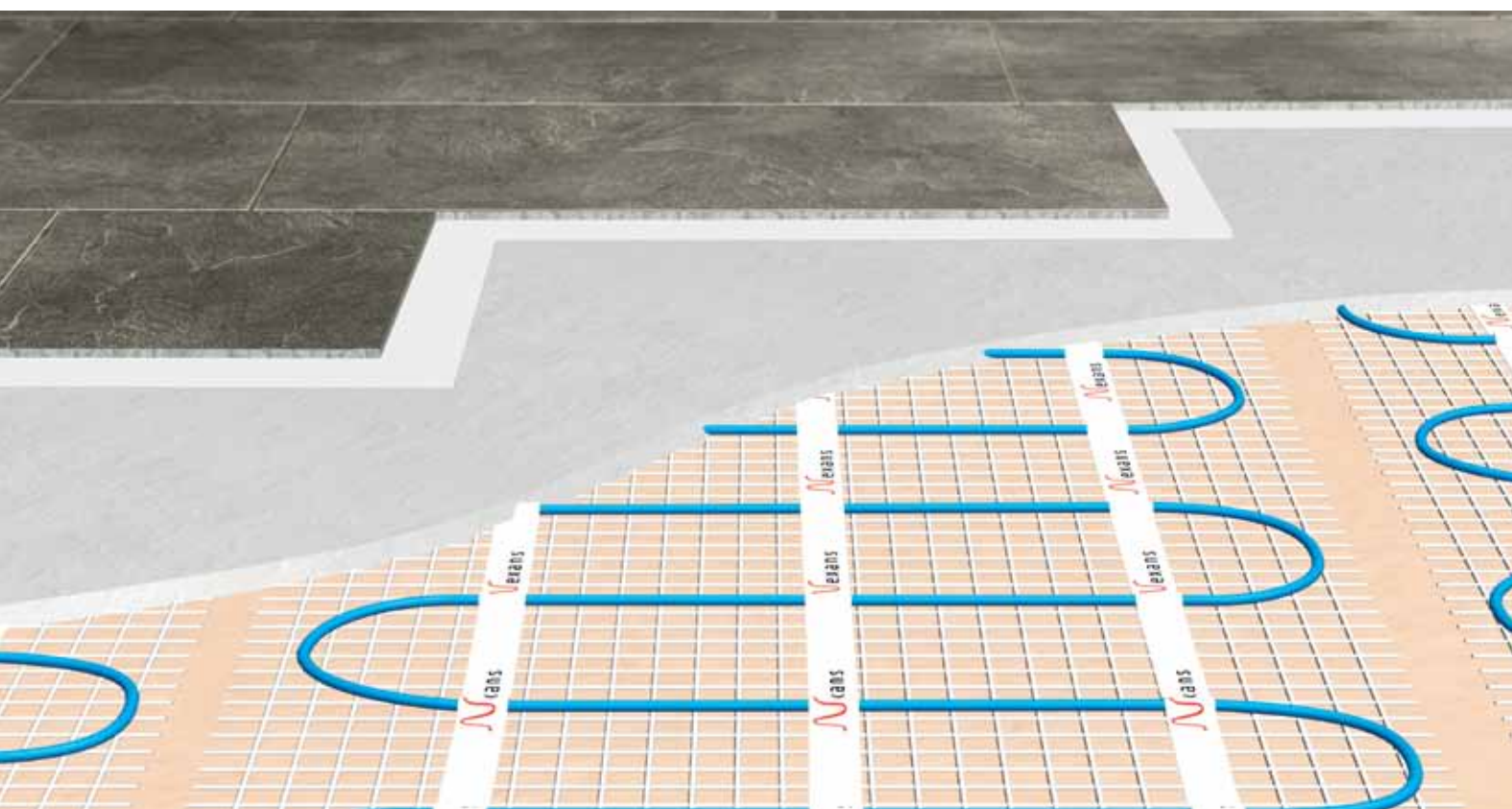
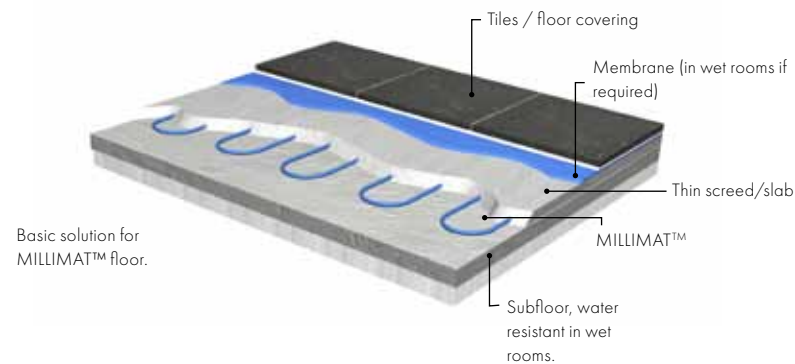

Nexans heating cables are perfect for snow and ice melting applications. Use series resistance general purpose heating cable, TXLP, DEFROST SNOW or SNOWMAT.

The amount of load to be installed is determined principally from what is required of the installation with regard to the climatic conditions and the control system.

In roads, driveways, sidewalks etc. the heating cable should be installed on a levelled base consisting of compacted stone/sand or similar. Top covering can be asphalt, concrete, or pavement blocks/stone. For ease of installation we suggest the use of SNOWMAT for outdoor snow and ice melting applications. When using traditional heating cables like the TXLP or DEFROST SNOW installed on an insulated base a wire mesh should be put on top of the insulation. Attaching the cables to this mesh will prevent the cables from being pressed/compacted into the insulation.

Special precautions with asphalt

For all outdoor installations, care must be taken when covering the heating cables. Do not drop stones or slabs on the heating cable. Asphalt should not have a higher temperature than approx 160 °C (320 °F).

The cable should first be covered manually by a thin layer of asphalt before the total thickness is laid and compacted with machinery/vehicles.

If the heating cables shall be moulded in concrete, it is important that the underlay is stable, and that the concrete is compacted.

The cables are normally covered by 50 mm (2") asphalt, concrete, or sand and pavement blocks.

Please see page 49 for recommended area outputs for snow and ice melting.

Section of Pavement with asphalt/concrete

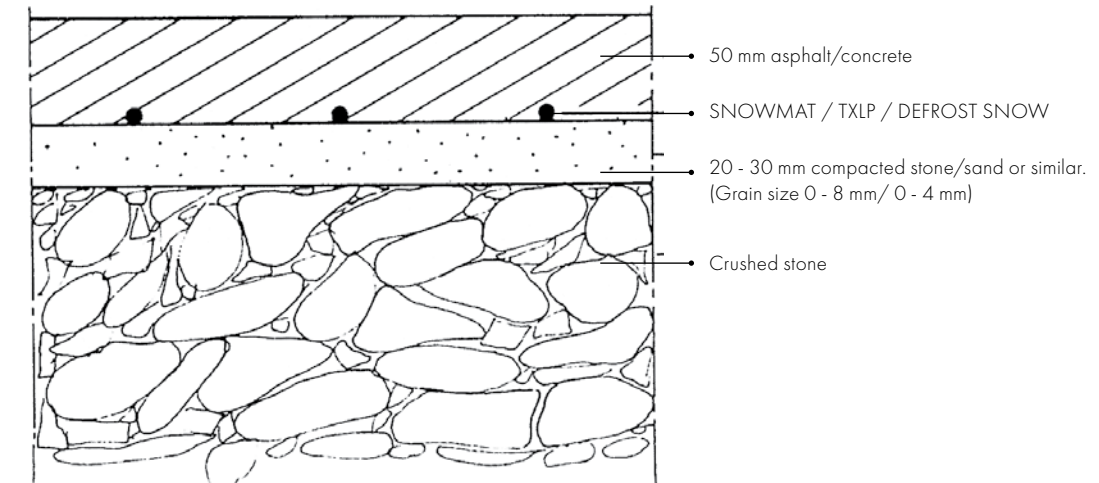

Section of area with pavement block/facing stone

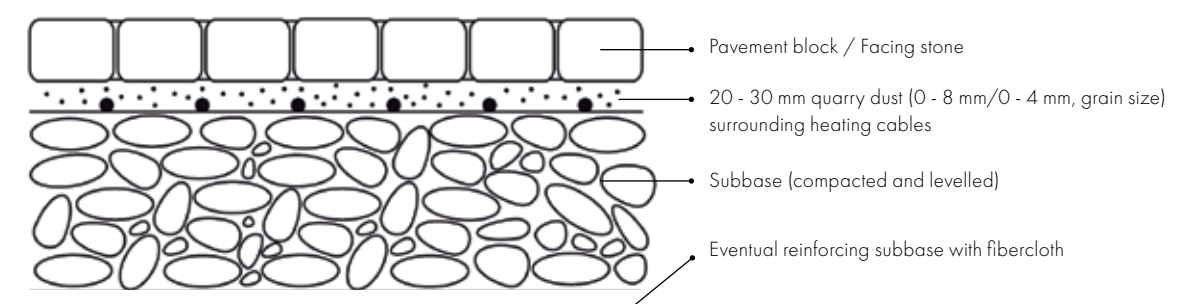

Heating cables in steps

Nexans heating cables in steps should be laid lengthways on the steps so that they lie only on the horizontal surfaces. The cables are covered with a 30 - 50 mm (1.2" - 2.0") concrete layer, or put into a layer of tile adhesive beneath stone or pavement blocks. Use DEFROST SNOW or TXLP with several cable runs in each step, so that C-C distance does not exceed 10 cm.

Limitations

With sand/slabs:	Max. 30 W/m (9 W/ft) of cable*
Asphalt:	Max. 30 W/m (9 W/ft) of cable
Concrete	Max. 35 W/m (10 W/ft) of cable

* If unsure about the sand's heat conductivity please limit the power to 28 W/m (8.5 W/ft)

Installation

The heating cable should be installed with even spacing. Avoid concentration of heating cable that will give uneven cable and surface temperatures and in worst case cause overheating and breakdown. Always measure insulation and conductor resistance before and immediately after covering the cables.

Be aware that the insulation resistance tends to become lower at high temperature, e.g. when measuring the cable in warm asphalt. Conductor resistance (ohm) increases with higher temperatures.

Frost protection of gutters and roof drains

Heating cables are ideal to prevent the build-up of ice and heavy snow in gutters and roof drains. It has an important safety aspect, as it prevents damage and injury that might be caused by falling snow, ice and icicles.

For this application, series resistance heating cable type TXLP or self-limiting heating cable type DEFROST PIPE 20/ Gutter is recommended.

Evaluate the roof construction: Warm or cold roof?

A warm roof is a poorly insulated roof where the heat loss through the roof construction causes a positive temperature on the roof surface under a layer of snow. Water from snow melting will end up in the cold roof drains and freeze.

A cold roof is a well insulated roof where the problem of ice is caused often in the late winter. Sunshine will melt the snow on the roof while the roof drains and gutters may be in the shadow. The melting water will then freeze.

Selecting the right load, recommendations:

Warm roof:
40 - 50 W/m of gutter
Cold roof:
30 - 40 W/m of gutter

Limitations: Output per meter gutter and linear output	
Metal gutters	Max. 50 W/m 15.2W/ft gutter, max. 25 W/m 7.6W/ft heating cable
Wooden gutters	Max. 36 W/m 11.0W/ft gutter, max. 18 W/m 5.5W/ft heating cable
Plastic gutters	Max. 40 W/m 12.2W/ft gutter, max. 20 W/m 6.1W/ft heating cable
Combustible base	Max. 18 W/m 5.5W/ft heating cable

No power limits for self limiting heating cable, DEFROST PIPE.

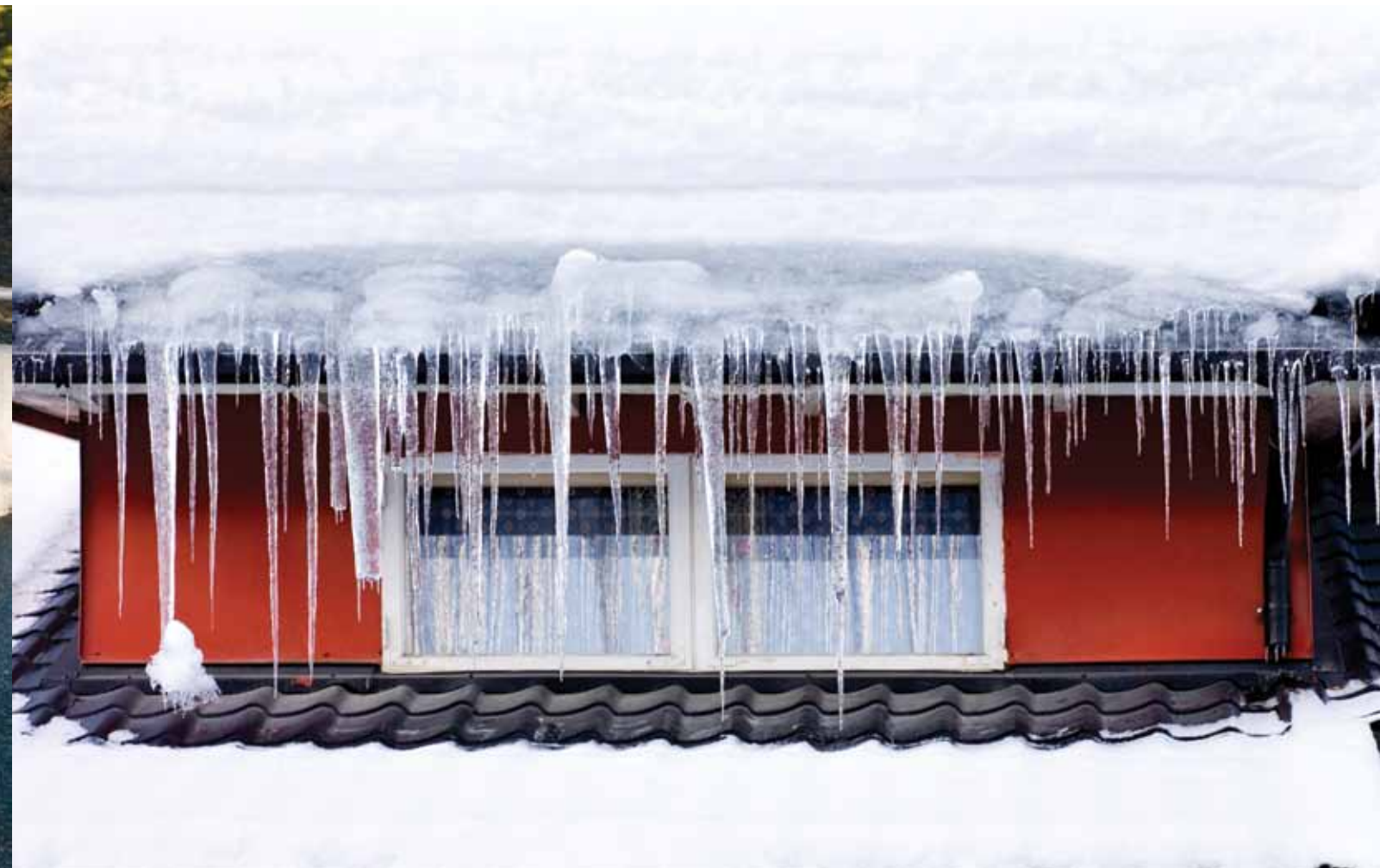

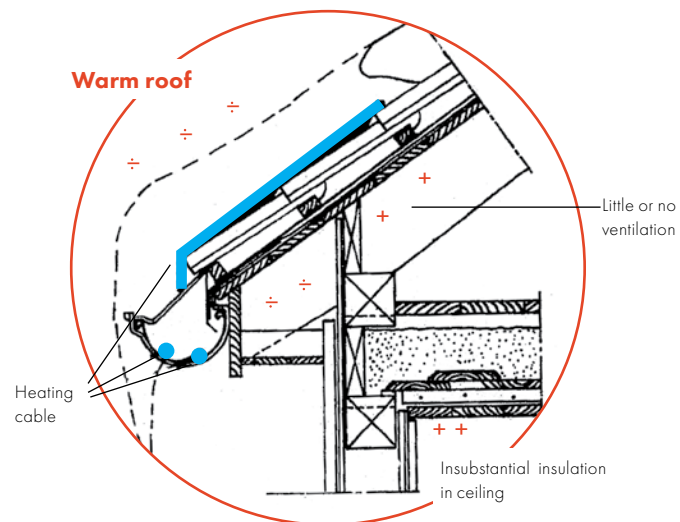

Planning and calculation

Due to the high loads and varying gutter and drain lengths, TXLP drum type single conductor cable is a good choice.

Sum up the total length of roof drain and gutters. If needed, the loop in the drain is to go down to frost proof depth.

Multiply this length by 2, and this gives the cable length and load. Select the correct length and resistance value by using the load diagram as showed in the appendix. As the cable is laid in a loop, the load per meter cable has to be the W/m roof drain/pipe divided by 2. Use the load diagram to find the desired cable length from the horizontal line and the correct load per meter cable from the resistance line.

The cable is installed in a continuous loop in the gutter/ drain. The cable is fastened on top of each drain by using a stainless steel suspension bracket. The loop is protected at the bottom opening as shown in the installation picture. For the control, use an outdoor waterproof thermostat placed on the shadow side of the building. The thermostat is to disconnect at approx. + 5 °C (41 °F). With cold roofs a thermostat disconnecting at approx. - 10 °C (14 °F) can also be used for energy saving purposes.

For even further energy savings, use an advanced control system. These systems often include two or three sensors (moisture, precipitation and temperature sensor) along with an advanced controller, making it possible to reduce energy consumption to a minimum.

It is required to use a ground fault circuit interrupter, along with a circuit breaker, disconnecting/tripping at max. 30 mA (for safety).

Cables on roof surfaces

In some difficult situations with warm roofs it may be necessary to install heating cable loops on the outer part of the roof in addition to the cable in the gutters/drains. The linear cable load is to be limited to 16 - 18 W/m per meter cable.

Example:

A 21 m long gutter with 2 drains, each 8 m. Total length is 37 m and we want approx. 40W/m gutter/drain. Cable length; $37 \times 2 = 74$ m. Cable linear load; $40/2 = 20$ W/m.

From the diagram we find that 74 m, 0.49 Ohm/m gives 20 W/m and 1450W total at 230V.

Self limiting heating cable, with DEFROST PIPE 20/GUTTER placing one length of the cable in the gutter is normally sufficient. Attach with asphalt glue if necessary.

Cold roof

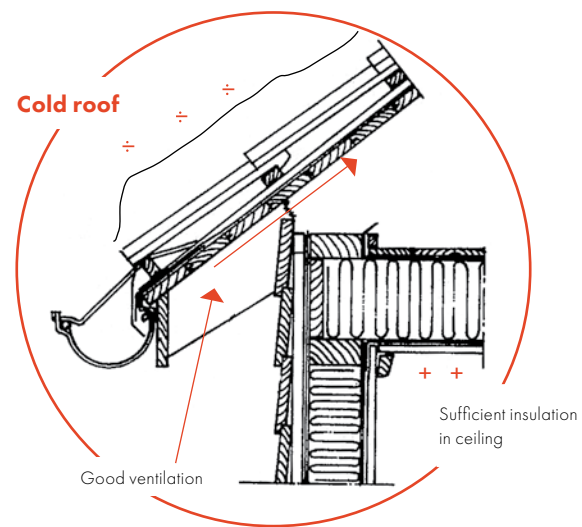

Frost protection of pipes and tanks

Choice of cable type

Usually for frost protection the cost efficient solution is to use TXLP on drum. Self limiting heating cables type DEFROST PIPE and DEFROST WATER can also be used, and prove practical in many cases. When using TXLP on drum it's important to take account for a maximum pipe temperature of 50 °C. In all cases regulation by thermostat is recommended. Choose a thermostat with external sensor, which will ensure low power consumption and an even temperature.

The following restrictions apply (TXLP):

Pipe temperature	Maximum power / meter (W/m)
Temp. = 45 - 50 °C	10
Temp. = 30 - 45 °C	15
Temp. = < 30 °C	20

Limitations for TXLP

TXLP cannot be used on pipes requiring a temperature above 50 °C (122 °F).

Calculation of required power in Watt

To do a calculation for choosing the correct heating cable(s) you need the following data:

- Pipe dimensions / Or the surface area of the tank
- Thermal insulation thickness
- The surrounding temperature
- Target temperature to keep on the tank or pipe

Unknown and non-controllable factors imply that you should adjust the results from your heat loss calculation a little upwards. A safety margin equal to a factor to 1.5 is not uncommon.

Insulated pipes

In general, pipes installed in air needs to be insulated. If not the heat loss will be quite high, even for small pipe diameters. For example, a non-insulated 1" water pipe will have a heat demand of 45 W/m at -30 °C.

Load demand, recommended loads for insulated pipes (W/m) surrounded by air

Inside pipe diam. Inches (")	Thickness of insulation																										
	15 mm			20 mm			25 mm			30 mm			40 mm			50 mm			100 mm								
	Δt °C			Δt °C			Δt °C			Δt °C			Δt °C			Δt °C			Δt °C								
	10	20	30	10	20	30	10	20	30	10	20	30	10	20	30	10	20	30	10	20	30	10	20	30			
3/4	3.5	6.5	11	3.1	5.5	8.0	2.5	5.5	7.0	2.5	4.5	6.5	2.0	3.5	5.0	1.5	2.5	3.5	1.5	2.5	3.5	1.5	2.5	3.5	1.5	2.5	3.5
1	4.0	8.0	12	3.5	7.0	10	3.0	6.0	9.0	3.0	5.0	8.0	2.5	5.0	7.0	2.0	4.0	6.0	1.5	3.0	4.0	1.5	3.0	4.0	1.5	3.0	4.0
1 1/4	5.0	10	15	4.0	8.0	12	4.0	7.0	10	3.0	6.0	9.0	3.0	5.0	8.0	2.5	5.0	7.0	2.0	3.0	5.0	2.0	3.0	5.0	2.0	3.0	5.0
1 1/2	5.5	11	16	4.5	9.0	13	4.0	8.0	11	4.0	7.0	10	3.0	6.0	8.0	2.5	5.0	7.0	2.0	3.5	5.0	2.0	3.5	5.0	2.0	3.5	5.0
2	6.5	13	19	5.0	10	15	5.0	9.0	13	4.0	8.0	12	3.0	6.0	9.0	3.0	6.0	8.0	2.0	4.0	6.0	2.0	4.0	6.0	2.0	4.0	6.0
2 1/2	8.0	16	24	6.0	12	18	5.0	10	15	5.0	9.0	13	4.0	7.0	11	3.0	6.0	9.0	2.0	4.0	6.0	2.0	4.0	6.0	2.0	4.0	6.0
3	9.0	18	27	7.0	14	21	6.0	12	17	5.0	10	15	4.0	8.0	12	4.0	7.0	11	2.5	4.5	7.0	2.5	4.5	7.0	2.5	4.5	7.0
4	11	22	33	9.0	18	27	8.0	15	22	6.0	12	18	5.0	10	15	4.0	8.0	12	2.5	5.0	8.0	2.5	5.0	8.0	2.5	5.0	8.0
5	14	28	42	11	21	31	8.0	17	25	7.0	14	21	6.0	12	17	5.0	10	15	3.0	6.0	9.0	3.0	6.0	9.0	3.0	6.0	9.0
6	15	30	45	12	24	36	10	20	30	9.0	17	25	7.0	14	21	6.0	11	17	3.5	7.0	10	3.5	7.0	10	3.5	7.0	10
7	17	34	51	14	28	42	11	22	33	10	19	29	8.0	15	22	6.0	12	18	4.0	8.0	11	4.0	8.0	11	4.0	8.0	11
8	20	40	59	15	30	45	13	25	37	11	21	32	9.0	17	25	7.0	14	21	4.0	8.0	12	4.0	8.0	12	4.0	8.0	12
9	22	43	64	17	34	51	14	27	40	12	23	35	10	18	28	8.0	15	23	4.5	9.0	13	4.5	9.0	13	4.5	9.0	13
10	23	46	69	19	37	55	15	30	45	13	26	39	10	20	30	8.0	16	24	5.0	10	14	5.0	10	14	5.0	10	14

Δt = temperature difference between the surroundings and the inside of the pipe.

Pipes buried in the ground

For pipes buried in the ground without thermal insulation you can use the following table to find the heat demand. The table shows the total heat demand in W/m and W/ft of the pipe.

Load demand, recommended loads for non-insulated pipes buried in the ground

Lowest winter air temperature -30 °C (-22 °F)							
Pipe diameter		Load requirements of pipe buried at different depths					
Inside Inches (")	Outside mm	500 mm 20"		800 mm 20"		1000 mm 20"	
		W/m	W/ft	W/m	W/ft	W/m	W/ft
1/2	21	6	2.0	5	1.5	5	1.5
3/4	27	8	2.5	7	2.0	6	2.0
1	33	10	3.0	8	2.5	7	2.0
1 1/4	42	12	3.5	10	3.0	9	3.0
1 1/2	48	14	4.5	11	3.5	10	3.0
2	60	17	5.0	14	4.0	12	3.5
2 1/2	75	21	6.5	17	5.0	15	4.5
3	89	25	8.0	21	6.5	18	5.5
4	114	32	10.0	26	8.0	23	7.0
6	165	46	14.0	38	12.0	33	10.0

The table show the load requirement per meter (W/m) or per feet (W/ft) of pipeline.

Single conductor TXLP heating cables should normally be used. The heating cable is laid back and forth in a loop. The linear load of the cable shall therefore be half the requirement per unit length of pipe as shown in the table. (TXLP cannot be used inside water pipes! For this application use self limiting cable DEFROST WATER.)

Tanks

The load demand for tanks are usually calculated and based on the following parameters:

U = Heat conductivity coefficient [W/Km²] (of the insulation)

A = Surface area of the tank

ΔT = Temperature difference between the inside of the tank and it's surroundings.

This calculation does not take account for warming up the contents of the tank, but rather maintain temperature against the "cold" outside.

Heat demand P

$$P = U \times A \times \Delta T$$

Installation in general for both pipes and tanks

The surface which the heating is installed on should be even without any sharp edges, and the heating cable should be in good contact with the surface along the entire length of the cable. Insulation should be protected against water intrusion.

Pipes

To keep a rational and even temperature around pipes with diameter less than 100 mm, it's normal to apply two cables along the pipe. With a single conductor this is easy by going back and forth on the pipe in a loop. For pipes with diameter larger than 100 mm it's normal to install four cables along the pipe to ensure even heat distribution. Heating cables can also be installed spiraled on the pipe. To choose the correct cable you can use the tables on page 51 and 52, 230V and 400V respectively.

Regardless of the type of the cable it should be fixed to the pipe for every 30 cm with glass fibre tape. After this the cable should be covered by aluminum tape or foil along the entire pipe length. This foil or tape ensures good thermal contact/conductivity to the tank or pipe. At valves and flanges the installation of cables should be so that disassemblies of these parts are possible without harming or cutting the heating cable.

The thermal insulation should be well protected against moisture and water intrusion. The screen/earth wire of the heating cable must be connected to the electrical system's earth. Electrical insulation of the heating cable is measured before and after applying thermal insulation.

Frost protection of freezer room (floors)

Using self limiting heating cables

After having found the heat loss, the following table is used to select the cable type:

Type	Output at 10 °C (W/m)	Most common application
DEFROST PIPE 10	10	Frost protection of pipes
DEFROST PIPE 15	15	Frost protection of pipes
DEFROST PIPE 20	20	Frost protection of pipes, roof gutters and drains
DEFROST PIPE 30	30	Frost protection of pipes
DEFROST PIPE 40	40	Frost protection of pipes

A self-limiting heating cable will adjust the heat output in response to increasing or decreasing pipe temperature. Due to this it is important to select the cable with the correct output depending on the temperature of the pipe. Check the operating pipe temperature and use the relevant diagrams in the product data sheet to select the correct cable temperature.

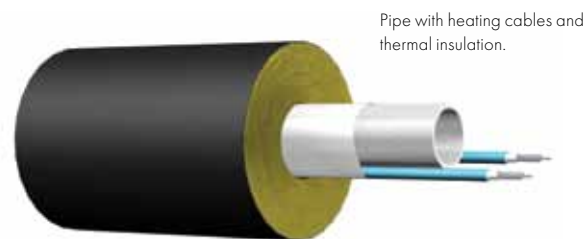
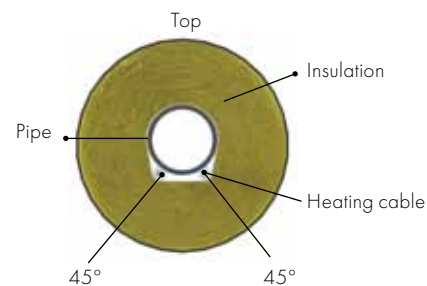

Installation

Self-limiting heating cables are normally laid straight along the pipe or spiralled in order to give the correct load. The heating cables are fixed to the pipe by means of a temperature resistant tape. The best thermal contact and heat distribution is achieved by wrapping an aluminium foil over the heating cable before the insulation is applied. The insulation must be suitably protected against moisture or water. On flanges and vents on process piping, 1 - 1.5 m (40 - 60") of heating cable is wrapped carefully in such a way that uncoupling can be done later if necessary.

Thermostat control

Thermostat control is recommended in order to maintain a steady temperature and save energy. An electronic thermostat with a remote sensor should be used.

Inrush currents

Self limiting heating cables are subject to inrush currents. This applies at the very moment the heating cables are turned on. As the cable is cold it will for a few seconds consume relative high power. For our defrost cables, you can use the following thumb rules:

- Temp. 10 °C: Inrush current = approx. 4x normal current
- Temp. -5 °C: Inrush current = approx. 5x normal current
- Temp. -20 °C: Inrush current = approx. 6x normal current

Type	Startup temperature	Max. length (m) at circuit breaker size (C/D-characteristic)			
		6 A	10 A	16 A	20 A
DEFROST PIPE 10	0 °C	64	106	160	160
DEFROST PIPE 15	0 °C	50	83	97	97
DEFROST PIPE 20/Gutter	0 °C	34	57	92	115
DEFROST PIPE 30	0 °C	27	45	71	89
DEFROST PIPE 40	0 °C	19	31	50	62

Use series resistance heating cable type TXLP

Selection of load

In freezer room floors, which are well insulated, the load requirement is 10 - 15 W/m² (1 - 1.5 W/Sq. ft).

Thermostat control

The heating cable should be controlled by use of a thermostat, with a remote sensor located at the same depth as the heating cable and between two cable runs.

Installation

Use a linear load of 5 - 10 W/m (1.5 - 3 W/ft) cable. The centre spacing will then be in the range of 50 - 70 cm (19 - 27"). The heating cable is normally embedded in a concrete layer before the floor is insulated and finished. Always measure the insulation and conductor resistance before embedding.

Tip!

As heating cables in freezer rooms are very difficult to access, installing an additional cable as a backup is sometimes performed

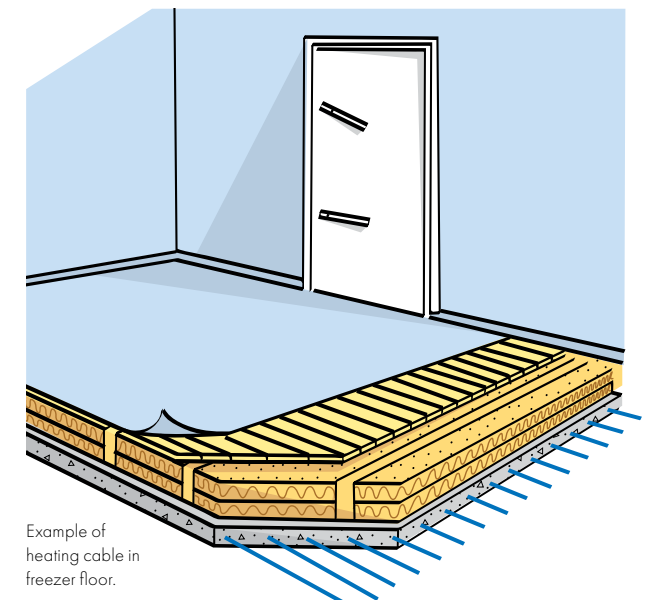

Sports fields and similar

Use series resistance heating cable type TXLP

Selection of load

For soil heating in green houses or similar, the load demand is approx. 5 W/m²/°C (0.26 W/Sq. ft/°F). In other words to raise the soil temperature 1 °C or 1.8 °F you need to install 5 W/m². For soil heating of sports arenas, the load is normally 50-90 W/m² (4.6-8.4 W/sq. ft).

With soil heating in sports arenas you are able to prolong the green season and make the grass grow faster. You can keep the ground frost free and melt some ice and snow. Note! During heavy snowfalls the load selection as specified above will not be sufficient to melt all snow and ice. (To have efficient snow melting you will need a standard snow melting installation with approximately 300W/m² of installed power).

Installation

Selection and location of heating cable as well as installation method have to be individually decided. normally the heating cables are placed 20-30 into the ground.

Note: Always measure the insulation and conductor resistance before embedding.

During installation it's important to keep focus on the stretch forces applied to the heating cable, especially if using a tractor or similar when installing. A little slack is good, and the sand surrounding the cables should not be coarse.

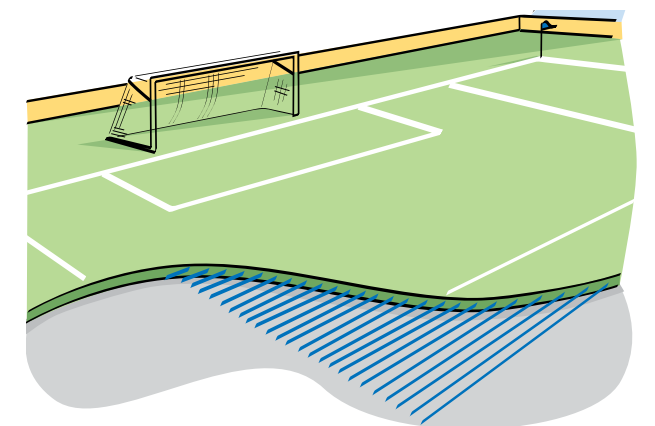

Drying and hardening of concrete

Electrical heating cables may be used for drying and hardening of concrete in new buildings. Hardening can prove difficult in cold climates, and by installing heating cables the hardening time will be reduced.

The shortening of the drying time will contribute to the shortening of the complete construction time which is economically advantageous. The heating cables are placed directly in the concrete. It prevents freezing and accelerates the hardening of the concrete and makes it possible to remove the frames after 72 hours, even in severe cold. At a later stage, the heating cables can be reconnected for effective drying of the building structure and providing basic heating during the construction period. With rapid drying of the concrete the painting work can begin earlier than with other heating methods.

Standard TXLP heating cables are often used for this purpose. Using a standard 230 V elements of 10 W/m connected to 400V is one possibility, giving an output of 30 W/m. For drying and hardening of concrete, a load of 85 - 135 W/m² is used. The cable is fixed to the armoring mesh, and should not cross or overlap at any point. The cable should not come in contact with plastic or combustible material.

The cables may be used at a later stage in the construction period and the cold leads are cut when the construction is completed.

Caution

It is not recommended to use heating cables for this purpose in environments with surrounding temperatures of 5 °C or higher.

Recommended installed power:

Outside Temperature °C	Area power W/m ²
0 to -5	95
-5 to -10	110
-10 to -15	130

The concrete should have a temperature of approx. 20 °C when poured. The heating cables should be turned on straight after the concrete has been poured. Hardening time is approx. 72 hours.

How to install

Use heating cable with linear output 30 - 35 W/m.

1. Calculate total power needed according to temperature and find total number of elements. Round up.
2. For each form where concrete shall be poured find the amount of cable to be installed. Attach the cable inside the form to the reinforcement mesh, cables shall not be closer to each other than 6 cm.
3. The entire length of the heating cable, including the splice connecting the cold lead, shall be embedded.
4. Remember the cable shall not be in contact with insulation, plastics, mineral wool or similar.
5. Place a temperature sensor (if necessary) in the middle between two heating cables.
6. Connect the heating cables to the power supply and check that the correct voltage is applied. Heating cables shall be protected by a earth fault protection device (RCD/GFCI) with a maximum trip level of 30 mA. Set the desired temperature if a thermostat is used. Finally check that the heating cable(s) are producing heat by measuring the current.

Hot water in buildings

Instant hot water supply by single pipe system can be achieved by using WARM WATER PIPE self-limiting heating cable for hot water temperature maintenance.

The WARM WATER PIPE self-limiting heating cable is fitted to a single hot water supply pipe to maintain the hot water temperature by compensating for the heat loss under non-flow condition.

Compared with a re-circulation system, this reduces the capital costs and lowers the operating costs.

Installation

Attach the heating cable to the water pipe by wrapping aluminium tape or foil all around the pipe and heating cable (see picture to the left). The aluminium will secure an even heat distribution. Then apply insulation around the aluminium foil/tape according to the table on page 45. This table shows the relation between insulation thickness, pipe diameter and corresponding maintenance temperature.

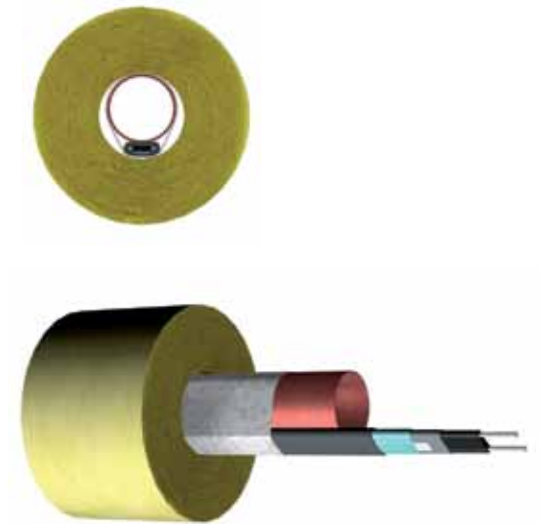

Part 3

Product information

Heating cables, series resistance

- 31** N-HEAT® TXLP/2R NORDIC
- 32** N-HEAT® TXLP/1
- 33** N-HEAT® TXLP drum cable
- 34** N-HEAT® MILLICABLE™
- 35** N-HEAT® MILLICLICK™
- 37** N-HEAT® DEFROST SNOW

Heating cable mats

- 38** N-HEAT® MILLIMAT™
- 40** N-HEAT® CABLEMAT
- 41** N-HEAT® SNOWMAT

Heating cables, self-limiting

- 42** N-HEAT® DEFROST PIPE / GUTTER
- 44** N-HEAT® DEFROST WATER AND DEFROST WATER KIT
- 45** N-HEAT® WARM WATER PIPE

Thermostats

- 47** N-HEAT® MILLITEMP™ thermostat
- 48** N-HEAT® COMFORT thermostat program
- 49** N-HEAT® N-ECO™ thermostat

Accessories

- 50** Accessories for heating cables
- 51** Accessories for self-limiting heating cables

N-HEAT® TXLP/2R NORDIC

Twin conductor heating cable units for direct heating



Applications:

TXLP/2R NORDIC heating cable units are ideal for floor warming in concrete constructions. They are also suitable for use in snow melting installations, for frost protection of roof gutters and drains, and soil heating. Each unit has a unique factory made integrated or hidden splice which is marked =>SPLICE<= on the cable surface. There is no need for a return conductor. The installation is simplified as the end of the cable can be placed wherever it is most convenient. The sealed end is 100% waterproof (factory made seal). The cold end is marked with *** on the cable surface.

Construction:

- Solid resistance wire and multistranded copper return wire
- XLPE insulation
- Tinned copper earthing conductor
- Aluminium screen
- PVC outer jacket
- Overall diameter: approx. 7.0 mm (0.28")

Technical data:

- Series resistance, element values from 200 to 3300 W
- Linear load: 10 or 17 W/m (3 or 5.2 W/ft)
- UV resistant
- Max. cont. operating temperature outer jacket: 65 °C (149 °F)
- Min. bending radius: 5 x cable diameter
- Tolerance on conductor resistance: - 5 / + 10 %
- Highest system voltage: 300/500 V
- Rated voltage: 230 V

TXLP/2R NORDIC– Twin conductor heating cable units 17 W/m and 10 W/m

TYPE	Load at 230V	Element length(*)		Nominal element resistance (Ω)	Outer diameter (mm)	Max magnetic flux density (μT)	Weight per unit		Nexans code no.	GTIN
	(W)	(m)	(ft)				(kg)	(lb)		
TXLP/2R 200/17	200	11.8	38,7	264,5	7,0	0,55	1,1	2,4	10224120	7045210068511
TXLP/2R 300/17	300	17,6	58	176,3	7,0	0,80	1,4	3,4	10224185	7045210068528
TXLP/2R 400/17	400	23,5	77	132,3	7,0	1,06	1,8	4,3	10224186	7045210068535
TXLP/2R 500/17	500	29,3	96	105,8	7,0	1,33	2,2	5,3	10224187	7045210068542
TXLP/2R 600/17	600	35,2	115	88,2	7,0	1,46	2,6	6,3	10224188	7045210068559
TXLP/2R 700/17	700	41,0	135	75,6	7,0	1,59	2,9	7,0	10224189	7045210068566
TXLP/2R 840/17	840	49,7	162	63,0	7,0	1,86	3,5	8,4	10224190	7045210068573
TXLP/2R 1000/17	1000	58,3	191	52,9	7,0	2,23	4,1	9,9	10224191	7045210068580
TXLP/2R 1250/17	1250	72,4	237	42,3	7,0	2,65	5,0	12,0	10224192	7045210068597
TXLP/2R 1370/17	1370	80,8	265	38,6	7,0	3,32	5,3	12,8	10224193	7045210068801
TXLP/2R 1700/17	1700	100,0	328	31,1	7,0	3,63	6,7	16,1	10224204	7045210068818
TXLP/2R 2100/17	2100	123,7	405	25,2	7,0	4,51	8,0	17,6	10224205	7045210068825
TXLP/2R 2600/17	2600	154,5	507	20,3	7,0	5,57	9,7	21,3	10224206	7045210068832
TXLP/2R 3300/17	3300	194,0	615	16,0	7,0	6,90	12,1	26,6	10224207	7045210068849
TXLP/2R 230/10	230	23,0	75	230,0	7,0	0,29	1,7	3,7	10224179	7045210068856
TXLP/2R 380/10	380	38,3	126	139,2	7,0	0,48	2,7	5,9	10224180	7045210068863
TXLP/2R 530/10	530	53,4	175	99,8	7,0	0,67	3,7	8,2	10224181	7045210068870
TXLP/2R 650/10	650	64,8	249,3	81,4	7,0	0,82	4,2	9,2	10224182	7045210068887
TXLP/2R 760/10	760	76,0	249	69,6	7,0	0,96	5,2	11,5	10224183	7045210068894
TXLP/2R 940/10	940	94,4	310	56,3	7,0	1,19	6,4	14,1	10224224	7045210068900
TXLP/2R 1050/10	1050	105,4	346	50,4	7,0	1,32	6,9	15,2	10224225	7045210068917
TXLP/2R 1300/10	1300	130,4	428	40,7	7,0	1,64	8,6	18,9	10224226	7045210068924
TXLP/2R 1610/10	1610	161,3	529	32,9	7,0	2,03	10,7	23,6	10224227	7045210068931

*In addition the products are delivered with a 2.3 m cold lead

N-HEAT® TXLP/1

Single conductor heating cable units for direct heating



Applications:

The heating cable units are ideal for direct floor warming in concrete constructions. They are also used in snow melting installations, for frost protection of roof gutters and drains, and soil heating. Each unit has a unique factory made integrated or hidden splice which is marked =>SPLICE<= on the cable surface.

Construction:

- Solid resistance wire
- XLPE insulation
- Tinned copper earthing conductor
- Aluminium screen
- PVC outer jacket
- Overall diameter: approx. 6.5 mm (0.26")

Technical data:

- Series resistance, element values from 750 to 1680 W, 10W/m (3W/ft) at 230 VAC
- Series resistance, element values from 300 to 3100 W, 17W/m (5.2W/ft) at 230 VAC
- UV resistant
- Max. cont. operating temperature outer jacket: 65 °C (149 °F)
- Minimum bending radius: 5 x cable diameter
- Tolerance on conductor resistance: -5 / +10 %
- Highest system voltage: 300/500 V
- Rated voltage: 230 V



TXLP/1 – Single conductor heating cable units 17 W/m and 10 W/m

Type	Load at 230V	Element length (*)		Nominal element resistance	Outer diameter	Weight xxper unit		Nexans code no.	GTIN
		(W)	(m)			(ft)	(Ω)		
TXLP/1 300/17	300	17.7	58.07	176.3	6.5	1.35	2.98	10022267	7045210013306
TXLP/1 400/17	400	23.5	77.10	132.3	6.5	1.61	3.55	10022269	7045210013320
TXLP/1 500/17	500	29.4	96.46	105.8	6.5	1.93	4.25	10022270	7045210013337
TXLP/1 600/17	600	35.3	115.81	88.2	6.5	2.26	4.98	10022271	7045210013344
TXLP/1 700/17	700	41.2	135.17	75.6	6.5	2.52	5.56	10022272	7045210013351
TXLP/1 850/17	850	50.0	164.04	62.2	6.5	3.03	6.68	10022273	7045210013368
TXLP/1 1000/17	1000	58.8	192.91	52.9	6.5	3.60	7.94	10022261	7045210013245
TXLP/1 1250/17	1250	73.5	241.14	42.3	6.5	4.36	9.61	10022262	7045210013252
TXLP/1 1400/17	1400	82.3	270.01	37.8	6.5	4.67	10.30	10022263	7045210013269
TXLP/1 1750/17	1750	102.9	337.60	30.2	6.5	5.99	13.21	10022264	7045210013276
TXLP/1 2200/17	2200	129.4	424.54	24.0	6.5	7.41	16.34	10022265	7045210013283
TXLP/1 2600/17	2600	156.0	508.53	20.3	6.5	8.48	18.70	10022266	7045210013290
TXLP/1 3100/17	3100	185.0	606.96	17.1	6.5	10.24	22.58	10022268	7045210013313
TXLP/1 750/10	750	76.7	251.64	70.5	6.5	4.61	10.16	10022904	7045210019568
TXLP/1 950/10	950	95.8	314.30	55.7	6.5	5.52	12.17	10070076	7045210030907
TXLP/1 1070/10	1070	107.4	352.36	49.4	6.5	5.99	13.21	10022901	7045210019520
TXLP/1 1340/10	1340	134.1	439.96	39.5	6.5	7.55	16.64	10022902	7045210019544
TXLP/1 1680/10	1680	168.9	554.13	31.5	6.5	9.27	20.44	10022903	7045210019551

*In addition the products are delivered with a 2.3 m cold lead in both ends

N-HEAT® TXLP

Single conductor general purpose heating cable on drums



Applications:

This heating cable is ideal for floor warming in concrete constructions. It is also used in snow melting installations, for frost protection of pipes, roof gutters and drains, and soil heating.

Construction:

- Stranded resistance wire
- XLPE insulation
- Tinned copper earthing conductor
- Aluminium screen
- PVC outer jacket
- Overall diameter: approx. 6.5 mm (0.26")

Technical data:

- Max. cont. operating temperature outer jacket: 65 °C (149 °F)
- Series resistance
- Minimum bending radius: 5 x cable diameter
- Tolerance on conductor resistance: -5 / +10 %
- Highest system voltage: 300/500 V
- UV resistant



TXLP on drum – Single conductor heating cable with specific resistance

Type	Linear resistance	Outer diameter	Weight per 100 m	Weight per 100 yds.	Nexans code no.	GTIN
TXLP 12.7 Ω/m	12.70	6.3	4.6	11.1	10156651	70452100154064
TXLP 7.7 Ω/m	7.70	6.0	4.6	11.1	10156650	70452100154057
TXLP 5.35 Ω/m	5.35	6.1	4.6	11.1	10156649	70452100154040
TXLP 3.5 Ω/m	3.50	6.1	4.9	11.8	10156648	7045210054033
TXLP 2.5 Ω/m	2.50	6.1	5.1	12.3	10156647	7045210054026
TXLP 1.4 Ω/m	1.40	6.3	5.0	12.0	10156646	7045210054019
TXLP 1.0 Ω/m	1.00	6.3	5.2	12.5	10156645	7045210054002
TXLP 0.7 Ω/m	0.70	6.9	5.1	12.3	10156644	7045210053999
TXLP 0.49 Ω/m	0.49	6.0	5.3	12.8	10156613	7045210053982
TXLP 0.3 Ω/m	0.30	6.0	5.3	12.8	10156612	7045210053975
TXLP 0.2 Ω/m	0.20	6.1	5.3	12.8	10156611	7045210053968
TXLP 0.13 Ω/m	0.13	6.5	5.6	12.5	10156610	7045210053951
TXLP 0.09 Ω/m	0.09	6.3	5.3	12.8	10156609	7045210053944
TXLP 0.07 Ω/m	0.07	6.1	5.3	12.8	10156608	7045210053937
TXLP 0.05 Ω/m	0.05	6.3	5.8	13.9	10156607	7045210053920
g	0.02	6.2	5.6	12.5	10156606	7045210053913

N-HEAT® MILLICABLE™

Thin twin conductor heating cable



Applications:

MILLICABLE is a thin twin conductor heating cable, which can be installed in a traditionally poured floor or together with MILLICLICK boards as a dry-floor heating system.

MILLICABLE is delivered spooled on a reel, packed in a user-friendly box. In addition the product comes with 5 m of aluminium tape for installation with MILLICLICK.

Construction:

- Solid resistance wires
- FEP insulation
- Solid, tinned copper drain wire
- Conductive polymer combined sheath and screen
- Moulded cold lead splice

Technical data:

- Output range from 120 W to 1170 W
- Tolerance on element resistance: -5 / +10 %
- Linear load: 6 W/m (1.83W/ft)
- Max. temperature energized, outer jacket: 65 °C (149 °F)
- Min. bending radius: 15 mm (0.6")
- Rated voltage: 230 VAC
- Maximum resistance of drain wire: 18.5 Ohm/km
- Length of cold lead: 3.5 m

MILLICABLE™ – Thin twin conductor heating cable units for direct heating

Load at 230V	Element length (*)	Nominal element resistance	Outer diameter	Weight	Covers in MILLICLICK	Nexans art. no.	GTIN
(W)	(m)	(Ω)	(mm)	(kg)	(m²)		
120	20	441.0	4.2	1.0	2	10127990	7045210048025
180	30	294.0	4.2	1.3	3	10196901	7045210061307
355	60	149.0	4.2	1.9	6	10127991	7045210048032
575	100	92.0	4.2	2.8	10	10127992	7045210048049
690	120	76.7	4.2	3.1	12	10127993	7045210048056
1170	200	45.2	4.2	4.7	20	10127994	7045210048063

* In addition the products are delivered with a 3.5 m cold lead.

N-HEAT® MILLICLICK™

Boards covered with aluminium foil and pre-cut slots for MILLICABLE

MILLICLICK boards are to be installed together with MILLICABLE. They are covered with aluminium foil and have pre-cut slots for MILLICABLE. The boards provide sound insulation between floors, and the aluminium foil ensures an even heat distribution. With MILLICABLE 6 W/m installed the system has a rated output of 60 W/m².

Construction:

- Size: 590 x 790 x 8 mm (width x length x thickness)
- Made of wooden fibres (environmentally friendly)
- Covered by aluminium foil

Technical data:

- Tracks for MILLICABLE, C-C approx. 10 cm
- Thermal insulation 7 W/m²K
- Sound insulation 19 dB

Table - MILLICABLE™ installed together with MILLICLICK™

Room area	Total output	MILLICABLE - thin twin conductor heating cable					
		120/6	180/6	355/6	575/6	690/6	1170/6
m²	W						
2 - 2,9	120	1					
3 - 4,9	180		1				
4 - 4,9	240	2					
5 - 5,9	300	1	1				
6 - 7,9	355			1			
8 - 8,9	475	1		1			
9 - 9,9	535		1	1			
10 - 11,9	575				1		
12 - 13,9	690					1	
14 - 14,9	810	1					1
15 - 15,9	870		1				1
16 - 17,9	930			1	1		
18 - 19,9	1045			1		1	
20 - 21,9	1170						1
22 - 23,9	1265				1	1	
24 - 25,9	1380					2	
26 - 27,9	1525			1			1
28 - 29,9	1620			1	1	1	
30 - 31,9	1745				1		1
32 - 33,9	1860					1	1
34 - 35,9	1955				1	2	
36 - 37,9	2070					3	
38 - 39,9	2215			1		1	1
40 - 41,9	2340						2
42 - 43,9	2435				1	1	1
44 - 46,0	2550					2	1

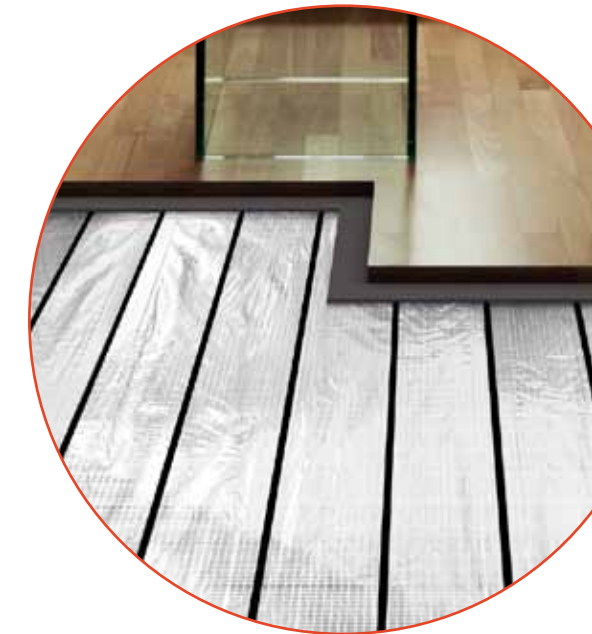

MILLICLICK boards

Description	Nexans code no.	GTIN	Thickness
MILLICLICK boards 590 x 790 x 8 mm (10 boards - 4,66 m)	10135472	7045210051308	8 mm



N-HEAT® DEFROST SNOW

Twin conductor TXLP cable for snow and ice melting



Applications:

DEFROST SNOW are ready made twin conductor heating cable elements for snow and ice melting applications such as driveways, courtyards, steps etc. The units can be installed directly in hot asphalt (160 °C/320 °F), or covered with concrete or flagstone and sand. DEFROST SNOW is equipped with a 10 m (32.8') cold lead and integrated splice.

Construction:

- Solid resistance wire
- XLPE insulation
- Tinned copper drain wire
- Aluminium armour screen
- PVC outer jacket
- Integrated cold end splice
- Overall diameter: approx. 7.0 mm (0.28")



Technical data:

- Output range from 640 W to 3400 W
- Tolerance on element resistance: -5 / +10 %
- Linear load: 28 W/m (8.5 W/ft)
- Length of cold lead: 10 m (32.8')
- Max. temperature energized, outer jacket: 65 °C (149 °F)
- Min. bending radius: 5 x cable diameter.
- Rated voltage: 230 VAC
- Max. temperature of hot asphalt: 160 °C (320 °F).
- UV resistant

DEFROST SNOW – Twin conductor heating cable for snow and ice melting

Output	Element length (*)	Nominal element resistance	Outer diameter	Weight.	Nexans code no.	GTIN
(W)	(m)	(W)	(mm)	(kg)		
640	22.9	82.7	7.0	2.3	10092292	704521003440
890	31.9	59.4	7.0	2.8	10092293	7045210034417
1270	45.4	41.7	7.0	3.7	10092324	7045210034424
1900	68.1	27.8	7.0	5.2	10092325	7045210034431
2700	96.4	19.6	7.0	7.0	10082427	7045210033113
3400	120.0	15.6	7.0	8.4	10070744	7045210030709

*In addition the products are delivered with a 10 m cold lead

N-HEAT® MILLIMAT™

Thin twin conductor heating cable mat

Applications:

MILLIMAT is ideal for renovation of all types of rooms, including bath-rooms. The mat consists of a twin conductor heating cable unit attached to a thin self-adhesive fibre-glass net. The outer diameter of the heating cable is approx. 4 mm. The heating cable unit is delivered with 2.5 m cold lead.

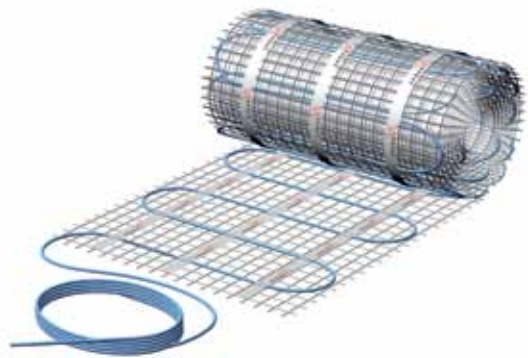

Construction:

- Conductor: Twin resistance wires
- FEP Insulation
- Solid copper earth wire
- Fibre-glass net
- PVC outer jacket
- Aluminium sheath
- Total thickness is 4.5 mm (0.18")
- Width 50 cm (19.7")

Technical data:

- Area load 100 or 150 W/m² (9.3 or 14.0 W/sq.ft.)
- Loads from 150 W to 1000 W
- Max. continuously operating temperature outer jacket: 100 °C
- Tolerance on conductor resistance: -5 / + 10 %
- Rated voltage: 230 V

Hidden splice

The hidden splice is as thin and robust as the cable itself, and eases the installation as it is not necessary to modify the subfloor when placing the splice.



MILLIMAT™ – 100 W/m²

Mat Area (m ²)	Output (W)	Mat Length (m)	Mat Width (m)	Element Resistance			Nexans code no.	GTIN
				Min (-5%)	Nominal	Max (+10%)		
1.0	100*	2	0.5	502.6	529.0	581.9	10143274*	7045210054507
1.5	150*	3	0.5	335.0	378.9	387.9	10143276*	7045210054514
2.0	200*	4	0.5	251.3	291.0	291.0	10143277*	7045210054521
2.5	250*	5	0.5	201.0	232.8	232.8	10143278*	7045210054538
3.0	300*	6	0.5	167.5	176.3	194.0	10143279*	7045210054545
3.5	350	7	0.5	143.6	151.1	166.3	10167423	7045210055917
4.0	400	8	0.5	125.6	132.3	145.5	10167644	7045210055924
5.0	500	10	0.5	100.5	105.8	116.4	10167645	7045210054931
6.0	600	12	0.5	83.8	88.2	97.0	10167646	7045210054948
7.0	700	14	0.5	71.8	75.6	83.1	10167647	7045210054955
8.0	800	16	0.5	62.8	66.1	72.7	10167648	7045210054962
10.0	1000	20	0.5	50.3	52.9	58.2	10167649	7045210054979
12.0	1200	24	0.5	41.9	44.1	48.5	10167650	7045210054986

* This mat size is not delivered with hidden splice

The products are delivered with a 2.5 m cold lead

MILLIMAT™ – 150 W/m²

Mat Area (m ²)	Output (W)	Mat Length (m)	Mat Width (m)	Element Resistance			Nexans code no.	GTIN
				Min (-5%)	Nominal	Max (+10%)		
1.0	150*	2.0	0.5	335.0	352.7	387.9	10224766*	7045210054637
1.5	225*	3.0	0.5	223.4	235.1	258.9	10224783*	7045210054644
2.0	300*	4.0	0.5	167.5	176.3	194.0	10224784*	7045210054651
2.5	375*	5.0	0.5	134.0	141.1	155.2	10224785*	7045210056006
3.0	450	6.0	0.5	111.7	117.6	129.3	10224786	7045210056013
3.5	525	7.0	0.5	95.7	100.8	110.8	10224787	7045210056020
4.0	600	8.0	0.5	83.8	88.2	97.0	10224788	7045210056037
5.0	750	10.0	0.5	67.0	70.5	77.6	10224789	7045210056044
6.0	900	12.0	0.5	55.8	58.8	64.7	10224790	7045210056051
7.0	1050	14.0	0.5	47.9	50.4	55.4	10224791	7045210056068
8.0	1200	16.0	0.5	41.9	44.1	48.5	10224792	7045210056075
10.0	1500	20.0	0.5	33.5	35.3	38.8	10224793	7045210060300
12.0	1800	24.0	0.5	27.9	29.4	32.3	10224794	7045210060317

* This mat size is not delivered with hidden splice

The products are delivered with a 2.5 m cold lead

N-HEAT® CABLEMAT

Twin conductor TXLP/2R cable mat for direct heating



Applications:

CABLEMAT is ideal for floor warming in concrete floor constructions. The units consist of twin conductor heating cable TXLP/2R attached to a thin, flexible glass fibre net. The units are equipped with a 4.5 m cold lead. Each unit has a unique factory made integrated splice which is marked =>SPLICE<= on the outer sheath. There is no need for a return conductor. The end seal is factory made, and 100% waterproof. The cold lead is marked with ***** on the outer sheath.

Construction:

- Solid resistance wire
- XLPE insulation
- Aluminium screen
- Tinned copper drain wire
- PVC outer jacket
- Overall diameter: Approx. 7.5 mm (0.3")
- Widths 40 and 80 cm

Technical data:

- Element values from 200 to 2100 W
- Linear load: 17 W/m (5,2 W/ft)
- Area load: 100 W/m² (9.3 W/sq.ft)
- Series resistance
- Max. cont. operating temperature outer jacket: 65 °C (149 °F)
- Min. bending radius: 5 x cable diameter
- Tolerance on element resistance: -5 / +10 %
- Rated voltage: 230 VAC
- IP class end seal: IPX7

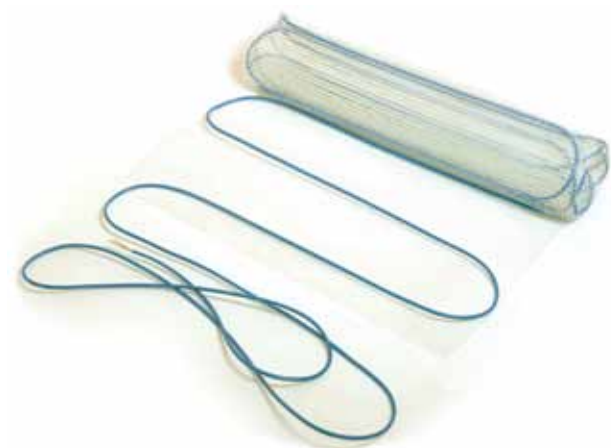

Output (W)	Mat width (m)	Mat length (m)	Mat area (m ²)	Min. room area (m ²)	Nominal element resistance (Ω)			Nexans code no.	GTIN
					Min. (-5%)	Nominal	Max. (+10%)		
200	0,4	4,9	2,0	2,2	251,0	264,5	291	10119571	7045210045406
300	0,8	3,5	2,8	3,0	167,5	176,3	193,9	10022430	7045210014938
400	0,8	4,6	3,7	3,9	125,7	132,3	145,5	10022431	7045210014945
500	0,8	5,7	4,6	4,8	100,5	105,8	116,4	10022432	7045210014952
600	0,8	6,8	5,4	5,6	83,8	88,2	97,0	10022433	7045210014969
700	0,8	7,9	6,3	6,5	71,8	75,6	83,2	10022434	7045210014976
840	0,8	9,6	7,7	7,9	59,9	63,0	69,3	10022435	7045210014983
1000	0,8	11,2	9,0	9,3	50,3	52,9	58,2	10022425	7045210014884
1250	0,8	13,9	11,1	11,4	40,2	42,3	46,5	10022426	7045210014891
1370	0,8	15,5	12,4	12,8	36,7	38,6	42,5	10022427	7045210014907
1700	0,8	19,1	15,3	15,7	29,5	31,3	4,2	10022428	7045210014914
2100	0,8	23,6	18,9	19,3	23,9	25,2	27,7	10022429	7045210014921
2600	0,8	29,4	23,5	24,0	19,3	20,3	22,4	10089402	7045210034004

N-HEAT® SNOWMAT

Twin conductor heating TXLP/2R cable mat with integrated splice

Applications:

Snowmat is ideal for quick installation of snow and ice melting in outdoor areas such as driveways, courts etc. It can be installed in hot asphalt, concrete or flagstone and sand. Comprises a twin conductor TXLP cable unit attached to a thin and flexible fibre glass net. Two mat widths, 40 cm for wheel tracks and small areas and 80 cm for large areas are available. The heating cable unit is delivered with integrated splice and 5.0 m cold lead.

Construction:

- Solid resistance wire
- XLPE insulation
- Tinned copper drain wire
- PVC outer jacket
- Aluminium sheath
- Overall diameter: approx. 7.5 mm (0.3")

Technical data:

- Element values from 1100 to 3300 W
- Linear load: 28 W/m (8.5 W/ft)
- Area load: 300 W/m² (27.9 W/sq.ft.)
- Series resistance
- Max. asphalt temperature: 160 °C (320 °F)
- Max. cont. operating temperature outer jacket: 65 °C (149 °F)
- Minimum bending radius: 5 x cable diameter
- Tolerance on conductor resistance: -5 / +10 %
- Rated voltage: 230 V



Output (W)	Mat width (m)	Mat length (m)	Mat area (m ²)	Nominal element resistance (Ω)	Nexans code no.	GTIN
1500	0,4	12,0	4,8	35,3	10035243	70452210026405
1800	0,4	14,5	5,8	29,4	10035244	70452210026412
2150	0,4	17,2	6,9	24,6	10035245	70452210026429
2600	0,8	11,0	8,8	20,3	10035246	70452210026436
3300	0,8	13,9	11,1	16,0	10035249	70452210026443

*In addition the products are delivered with a 5 m cold lead

N-HEAT® DEFROST PIPE/GUTTER

Self-limiting heating cable



Applications:

DEFROST PIPE is a light commercial grade self-limiting heating cable that is ideal for frost protection of pipes, tanks, roof gutters and drains. It can be cut-to-length on site within the given limitations, and exact lengths can be fitted without any complicated design considerations. Its self-limiting characteristics improve safety and reliability. DEFROST PIPE will not overheat or burnout, even when overlapped upon itself. The output is self-limiting in response to the pipe temperature.

DEFROST PIPE 20/GUTTER is suitable for roof gutters and drains, and may be regarded as a universal cable for this field of use.

Construction:

- Nickel-plated copper bus wires
- Semi conductive polymer matrix
- Insulation: cross-linked TPE
- Aluminium screen
- Tinned copper drain wire
- Polyolefin outer jacket

Technical data:

- Min. installation temperature: -45 °C (-49 °F)
- Max. temperature energized, outer jacket: 65 °C (149 °F)
- Max. temperature de-energized, outer jacket: 80 °C (176 °F)
- Exception DEFROST PIPE 15 max. temperature de-energized, outer jacket: 65 °C (149 °F)
- Min. bending radius: 25 mm
- Rated voltage: 230 VAC
- UV resistant

DEFROST PIPE/GUTTER - Maximum cable lengths and corresponding circuit breakers at different temperatures.

Type	Temp (°C)	Max length [m] and circuit breaker size (C/D-characteristic)					
		6 A	10 A	16 A	20 A	25 A	32 A
DEFROST PIPE 10	+10	77	128	177	177	177	177
	0	64	106	160	160	160	160
	-10	54	90	144	149	149	149
	-20	47	78	125	139	139	139
	-40	37	62	99	124	124	124
DEFROST PIPE 15	+10	59	98	105	105	105	105
	0	50	83	97	97	97	97
	-10	43	72	91	91	91	91
	-20	38	64	85	85	85	85
	-40	31	52	77	77	77	77
DEFROST PIPE 20 / GUTTER	+10	41	68	109	129	129	129
	0	34	57	92	115	119	119
	-10	30	50	79	99	111	111
	-20	26	44	70	87	104	104
	-40	21	35	56	71	88	93
DEFROST PIPE 30	+10	31	52	83	104	113	113
	0	27	45	71	89	105	105
	-10	23	39	63	78	98	98
	-20	21	35	56	69	87	87
	-40	17	28	45	57	71	83
DEFROST PIPE 40	+10	22	36	57	71	89	94
	0	19	31	50	62	78	88
	-10	17	28	44	55	69	83
	-20	15	25	40	50	62	78
	-40	13	21	33	42	52	71

DEFROST PIPE with aluminium foil screen

Type AO Aluminium foil screen	Output at 10 °C	Outer dimension		Bus bar cross section	Weight	Nexans code no.	GTIN
	(W/m)	Width (mm)	Height (mm)				
DEFROST PIPE 10	10	13.6	5.5	2 x 1.23	9.1	10182113	7045210059007
DEFROST PIPE 15	15	8.0	5.5	2 x 0.56	5.3	10174809	7045210056402
DEFROST PIPE 20 / GUTTER	20	13.6	5.5	2 x 1.23	9.1	10174810	7045210056419
DEFROST PIPE 30	30	13.6	5.5	2 x 1.23	9.1	10174811	7045210056426
DEFROST PIPE 40	40	13.6	5.5	2 x 1.23	9.1	10182504	7045210059014

For self limiting heating cables totally surrounded by ice/water the following restrictions apply (maximum length):

Temperature when connecting (°C)	Circuit-breaker (A)	Length (m) DE-FROST PIPE 20	Length (m) DE-FROST PIPE 10	Temperature when connecting (°C)	Circuit-breaker (A)	Length (m) DE-FROST PIPE 20	Length (m) DE-FROST PIPE 10	Temperature when connecting (°C)	Circuit-breaker (A)	Length (m) DE-FROST PIPE 20	Length (m) DE-FROST PIPE 10
10	10	34,5	74	0	10	29	61,5	-30	10	29	61,5
	16	55	89,5		16	46,5	89,5		16	46,5	89,5
	20	69	89,5		20	58	89,5		20	58	89,5
	25	86	89,5		25	72,5	89,5		25	72,5	89,5
	32	100,5	89,5		32	93	89,5		32	93	89,5
	40	100,5	89,5		40	100,5	89,5		40	100,5	89,5

DEFROST PIPE with braided screen

Type BO Braided screen	Output at 10 °C	Outer dimension		Bus bar cross section	Weight	Nexans code no.	GTIN
	(W/m)	Width (mm)	Height (mm)				
DEFROST PIPE 10	10	13.6	5.8	2 x 1.23	10.8	10182505	7045210059021
DEFROST PIPE 15	15	8.5	5.8	2 x 0.56	6.2	10182506	7045210059038
DEFROST PIPE 20 / GUTTER	20	13.6	5.8	2 x 1.23	10.8	10182507	7045210059045
DEFROST PIPE 30	30	13.6	5.8	2 x 1.23	10.8	10182508	7045210059052
DEFROST PIPE 40	40	13.6	5.8	2 x 1.23	10.8	10182509	7045210059069

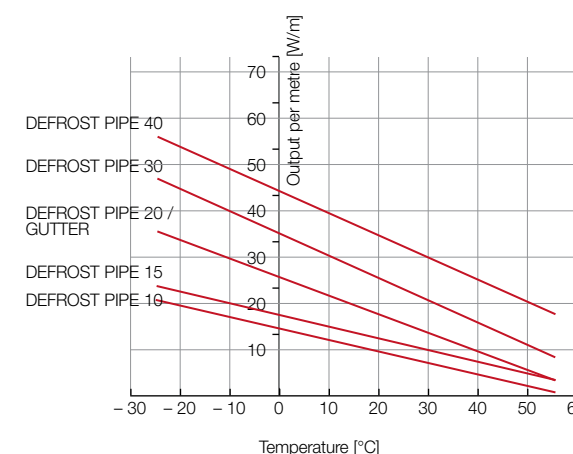

N-HEAT® DEFROST WATER and DEFROST WATER KIT

Self-limiting heating cable for installation in drinking water pipes



Applications:

DEFROST WATER is a halogen free self limiting heating cable that is ideal for frost protection of drinking water pipes, suitable for installation inside the pipe. The outer sheath material is approved for this use. While DEFROST WATER is an "on drum" heating cable, DEFROST WATER KIT comes in specific lengths with end seal, splice and a cold lead with plug (standard European, with ground).

DEFROST WATER can be cut to any length on site within the given limitations, and exact lengths can be fitted without any complicated design considerations. The fixed length of DEFROST WATER KIT is not intended to be modified.

The output is self limiting in response to the pipe temperature, however it is recommended to use a thermostat to control the cable to avoid unnecessary operation, for example during summer.

Construction:

- Tinned copper bus wires
- Semi conductive polymer matrix
- PE insulation
- Aluminium screen
- Tinned copper drain wire
- PE outer jacket

Technical data:

- Max. temperature energized, outer jacket: 45 °C (113 °F)
- Min. installation temperature: -10 °C (14 °F)
- Min. bending radius: 15 mm (0,6")
- Rated voltage: 230 VAC
- Max. circuit breaker size: 10 A
- Max. resistance of drain wire: 18.5 Ohm/km

Type*	Weight kg	Nexans art. no.	GTIN
DEFROST WATER KIT 3 m	0,40	10206608	7045210063301
DEFROST WATER KIT 5 m	0,55	10206609	7045210063318
DEFROST WATER KIT 7 m	0,65	10206610	7045210063325
DEFROST WATER KIT 10 m	0,85	10206611	7045210063332
DEFROST WATER KIT 15 m	1,20	10206612	7045210063349
DEFROST WATER KIT 20 m	1,50	10206613	7045210063356
DEFROST WATER KIT 25 m	1,85	10206624	7045210063363

* DEFROST WATER KIT has otherwise the same characteristics as DEFROST WATER below.

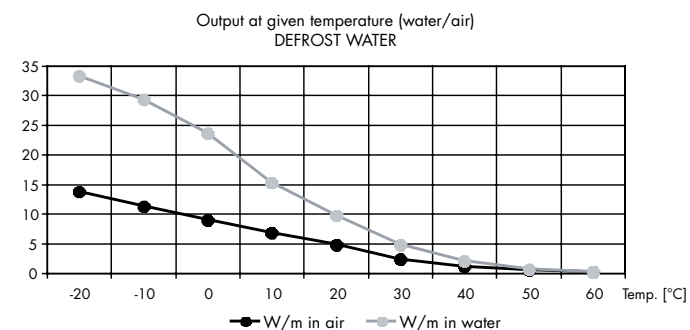

Type	Output at 5 °C	Outer dimension	Bus bar cross section	Weight	Max length	Nexans code no.	GTIN
	(W/m)						
DEFROST WATER	18.5 in water 9 in air	7.0	2 x 0.5	6.1	60 in water 100 in air	10064795	7045210030303

Type	Temp.	In-rush current	Max. length [m] Circuit breaker size 10 A In water	Max. length [m] Circuit breaker size 10 A In air
	(°C)			
DEFROST WATER	5	0.2	60	100
	0	0.3	54	90
	-10	0.4	42	70
	-20	0.5	30	50
	-30	0.7	24	40

N-HEAT® WARM WATER PIPE

Self-limiting heating cable for temperature maintenance of hot water pipes



Applications:

WARM WATER PIPE is a commercial grade self-limiting heating cable that is ideal for temperature maintenance of hot water pipes. WARM WATER PIPE is used to keep the pipe temperature at approx. 55 °C (131 °F). It can be cut-to-length on site within the given limitations, and exact lengths can be fitted without any complicated design considerations. Its self-limiting characteristics improve safety and reliability. WARM WATER PIPE will not overheat or burnout. The output is self-limiting in response to the pipe temperature.

Construction:

- Nickel-plated copper bus wires
- Semi conductive polymer matrix
- XLPE insulation
- Aluminium screen
- Tinned copper drain wire
- Polyolefin outer jacket

Technical data:

- Max. temperature energized, outer jacket: 80 °C (212 °F)
- Max. temperature de-energized, outer jacket: 100 °C (248 °F)
- Min. bending radius: 15 mm (0,6")
- Rated voltage: 230 VAC
- Max. circuit breaker size: 20 A
- Max. resistance of drain wire: 18.5 Ohm/km

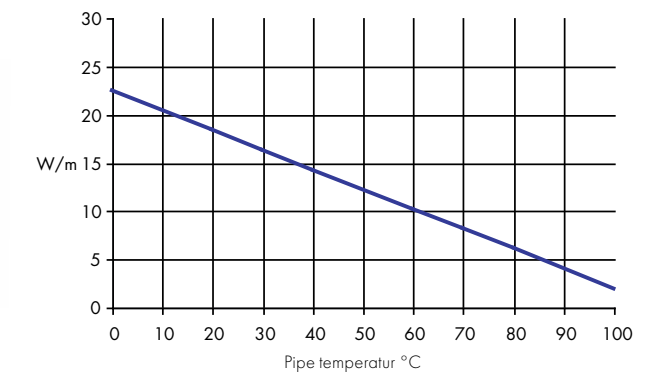
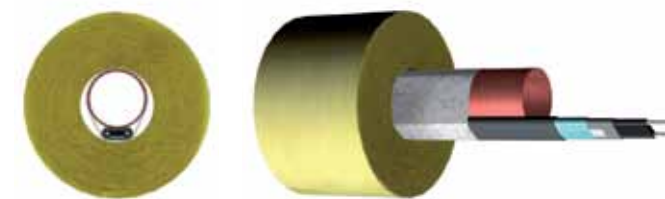

Type	Output at 55 °C	Outer dimension		Bus bar cross section	Weight	Max length	Nexans code no.	GTIN
	(W/m)	Width	Height					
WARM WATER PIPE	9	11.6	5.1	2 x 1.23	9.0	120	10061634	7045210028744

Circuit breaker size	6 A	10 A	16 A	20 A
	Max. length	30	50	80

Maintenance temp.	Pipe diameter (mm)					
	15	20	28	35	42	54
55	20	20	25	30	37	50
50	12	12	19	25	25	37

Based on a thermic insulation with a K-value = 0,038 W/mK
< Recommended insulation
< Recommended thickness

N-HEAT® MILLITEMP™ Thermostat for comfort heating

Applications:

Precise and accurate temperature control is important to fully achieve the advantages of floor heating without using more electric energy than necessary. Heating cables in combination with an accurate thermostat are probably the most energy efficient heating system one can have in a modern building.

The design of the thermostat is unique, and every detail has been carefully designed paying special attention to aesthetic appearance, user-friendliness and quality, as required and demanded by both consumers and professional installers.

Features:

- Large screen with blue backlighting
- 4-event programme or constant temperature control
- Clock: 12 hours (am/pm) / 24 hours
- Day display: Monday - Sunday
- Sensor: Floor/room or combined with limiting function
- Celsius or Fahrenheit display selection
- Frost protection mode
- 5 to 40 °C working range (default)

Specifications:

- Accuracy: +0.5 °C / 1 °F
- Maximum load: 16A
- Power supply: 230V
- Dimensions: 86 x 86 x 13 mm (WxHxD)
- IP 21



Type	Nexans code no.	GTIN
Thermostat MILLITEMP digital CDFR-003 EN	10175393	7045210059809

N-HEAT® N-COMFORT Thermostat programme

The N-COMFORT thermostat programme adds a powerful dimension to Nexans' heating system portfolio.

Precise and accurate temperature control is important to fully achieve the advantages of floor heating without using more electric energy than necessary.

In addition to the thermostats being easy to install and adjust, the temperature is digitally controlled by software specifically developed for underfloor heating systems.

The N-COMFORT series comprises four different controllers – three thermostats and one power regulator. Whatever your need is, you will find a N-COMFORT controller optimal for your needs. From just simple power control to advanced day/night control, N-COMFORT will do the job!



Type	Nexans art. no.	GTIN
Regulator N-COMFORT electronic CR-001	10146279	7045210054835
Thermostat N-COMFORT electronic CEF-001	10126416	7045210052828
Thermostat N-COMFORT digital CDFR-001	10126415	7045210054804
Thermostat N-COMFORT digital CDFR-002	10146278	7045210054811

	CDFR-001	CDFR-002	CEF-001	CR-001
Description:	Programmable digital thermostat with room and floor sensor and day/night function. Floor sensor default.	Identical to CDFR-001, but with pre-programmed day and night saving function. Room sensor default.	Electronic thermostat with room and floor sensor without day/night function	Power regulator
Applications:	For indoor use in all room types	For indoor use in all room types	For indoor use in all room types	For indoor use. Recommended in small rooms
Technical data:				
Rated Voltage	230 VAC, 50 Hz	230 VAC, 50 Hz	230 VAC, 50 Hz	230 VAC, 50 Hz
Max. load	3600 W, 16 A	3600 W, 16 A	3600 W, 16 A	3600 W, 16 A
IP Class	IP21	IP21	IP21	IP21
Temperature scale	+5 to +37 °C	+5 to +37 °C	+5 to +37 °C	N/A
Accuracy	0.4 °C	0.4 °C	0.4 °C	N/A
Max. circuit breaker size	16 A	16 A	16 A	16 A
Length of floor sensor	3 m	3 m	3 m	N/A
On/off-switch	Two-pole	Two-pole	Two-pole	Two-pole
Regulating period	N/A	N/A	N/A	30 min.
Temperature limitation	Yes	Yes	Yes	No
Factory sensor setting	Floor	Room	Floor	N/A
Self-learning function	Yes	Yes	No	N/A

N-HEAT® N-ECO™ Intelligent temperature control

Applications:

Precise temperature control is important to fully achieve the advantages of floor heating without using more electric energy than necessary. Heating cables in combination with an advanced thermostat is a very energy efficient system, which puts you in control.

The N-ECO thermostat is developed and manufactured according to European standards. The French market will be the primary market, as the thermostat has a "fil pilote" function, but the thermostat will work fine without the "fil pilote" signal also.

Features:

- Large screen with backlighting
- Fil pilote, 6 different commands (French standard)
- Three modes of possible regulation:
- Built-in sensor - Room temperature control
- Built-in sensor - Room temperature control with floor sensor used to limit floor temperature
- External sensor - Floor temperature control
- Calibration function
- Display setting: Level (0-9) or temperature
- "First heating" function, for first time use
- Adjustable setback temperature for ECO mode

Specifications:

- Rated voltage 230V~ (+10% / -15%)
- Operating temperature 0 – 40 °C
- IP class 31
- EN 60730
- eu.bac approved, rating CA 0,5
- Output 3400W (16A relay, 230V)
- Dimensions HxWxD = 87x85x18 mm (22mm depth into wallbox)



Type	Nexans code no.	GTIN
N-ECO thermostat 16A	10207636	7045210064209
N-ECO thermostat 16A + floor sensor	10208547	7045210064308

ACCESSORIES for N-HEAT® heating cables

The following accessories are available.

Type designation	Description	Suitable for the following cables	Nexans code no.	GTIN
1. Suspension bracket	Stainless steel suspension bracket for heating cable in roof drains.	TXLP	10191134	7045210029949
2. Spacer strip (galvanized steel)	Galvanized spacer strip for heating cables in floors and outdoor applications. May also be used in gutters.	TXLP	10191073	7045210030402
3. Plastic spacers	Plastic spacers for heating cable in roof drains and gutters.	TXLP	10068944	7045210030501
4. Splice kit 1.5 - 2.5 mm ² (4 splices)	Splice kit for single conductor heating cable to cold lead 1.5 - 2.5 mm ² .	TXLP drum types	10066638	7045210030204
5. Splice kit 4.0 - 6.0 mm ² (2 splices)	Splice kit for single conductor heating cable to cold lead 4.0 - 6.0 mm ² .	TXLP drum types	10066639	7045210030228
6. TXLP cold lead 1 x 2.5 mm ²	Cold lead for heating cable	Coil (50 m)	10180293	7045210058208
TXLP cold lead 1 x 2.5 mm ²	Cold lead for heating cable	Drum (1000 m)	10180292	7045210058192
TXLP cold lead 1 x 4 mm ²	Cold lead for heating cable	Drum (1000 m)	10180314	7045210058215

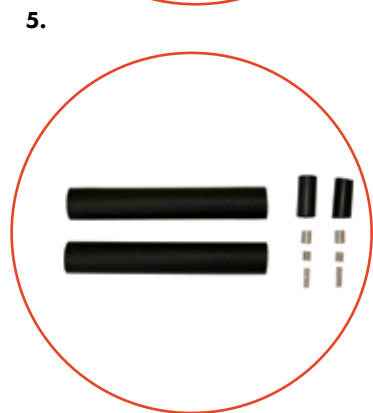
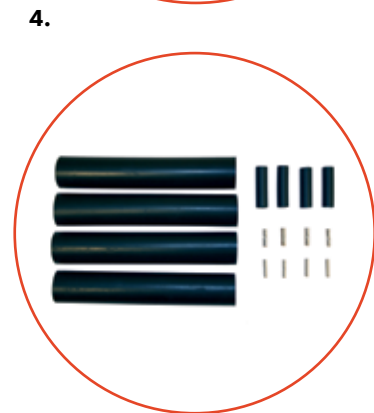
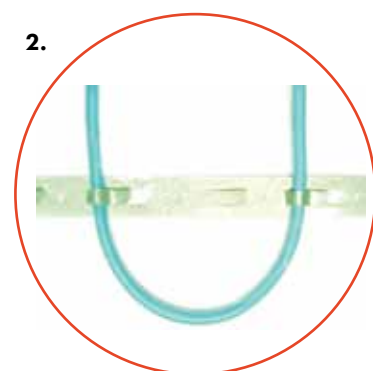
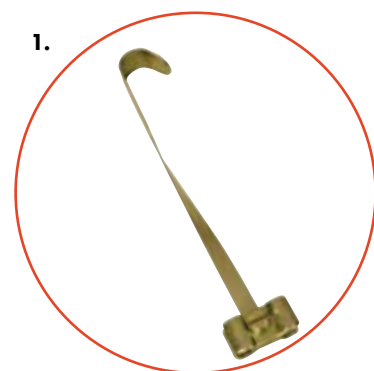

ACCESSORIES for self-limiting heating cables

The following accessories are available for our self limiting heating cables:

Type designation	Suitable for the following cables	Nexans code no.	GTIN
1. Glass-fibre fixing tape	DEFROST PIPE, WARM WATER PIPE	10068945	7045210030518
2. Splice, end termination and connection kit	DEFROST PIPE, WARM WATER PIPE	10072993	7045210031508
3. Aluminium fixing and heat distribution tape, W=50 mm L=50 m	DEFROST PIPE, WARM WATER PIPE	10021005	7045210030273
4. Brass gland 3/4", watertight	DEFROST WATER, DEFROST WATER KIT	10212358	7045210065909
5. End termination kit, watertight	DEFROST WATER	10066641	7045210030242

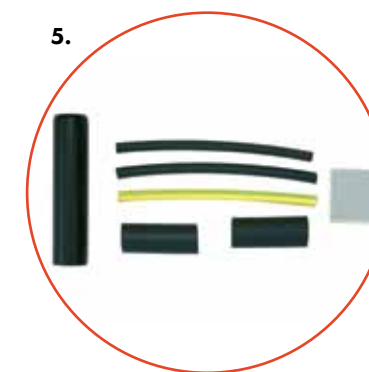
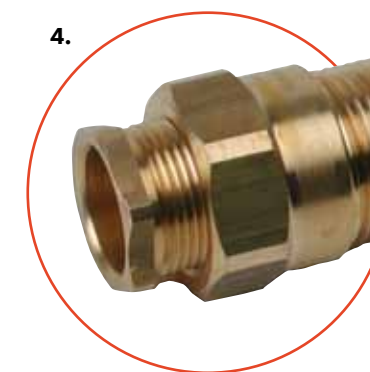
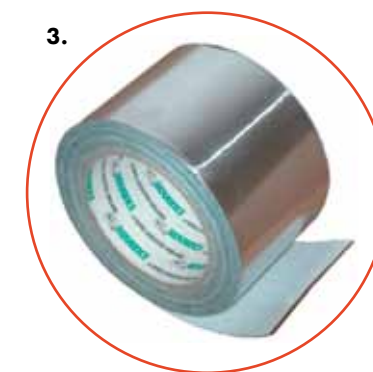
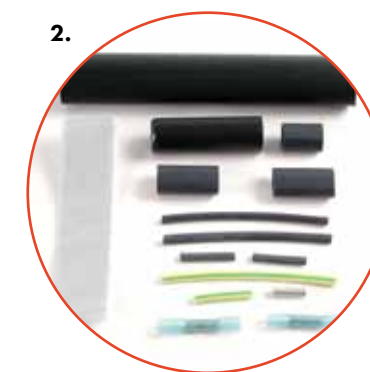
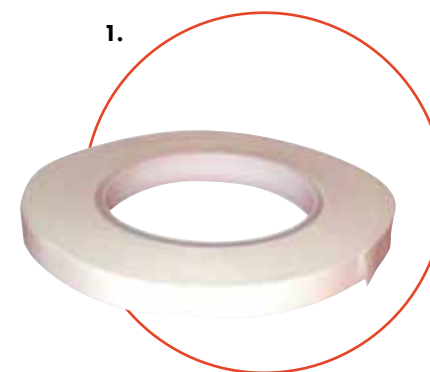

Areas of use of Nexans heating cables

By using the factory made heating cable elements, of e.g. 17 W/m (5.2 W/ft), the calculation of the centre spacing is simplified. The correct centre spacing (c-c distance) describes the distance between the cable loops.

53 Areas of use for Nexans Heating Cables

54 Selection table TXLP/2R 10 W/m

55 Selection table TXLP/2R 17 W/m

56 Load diagram 120V

57 Load diagram 230V

58 Load diagram 400V

Application	Output [W/m ²]		Product							
	Max	Normal	TXLP elements	TXLP drum	MILLIMAT 100 W/m ²	MILLIMAT 150 W/m ²	MILLICABLE 60 W/m ²	MILLICABLE FLEX elements	SNOWMAT DEFROST SNOW	Self-limiting
Comfort heating:										
Living room	100	70-100	X		X		X	X		
Kitchen	100	70-100	X		X		X	X		
Bedroom	100	70-100	X		X		X	X		
Children's room	100	70-100	X		X		X	X		
Basement family room	100	70-100	X		X		X	X		
Bathroom	150	120-150	X			X		X		
WC	150	120-150	X			X		X		
Laundry room	150	120-150	X			X		X		
Hall/Corridor	150	80-100	X		X		X	X		
Entrance/Hall	150	80-100	X		X		X	X		
Entrance/Porch	150	120-150	X			X		X		
Basic heating	100	40-60	X				X	X		
Daycare		50-70	X				X	X		
Office	100	80-100	X		X		X	X		
Storage room	100	80-100	X		X			X		
Shop	100	80-100	X		X			X		
Workshop	100	80-100	X		X			X		
Snow melting:										
Street		250-350	X	X						
Sidewalk		250-350	X	X					X	
Ramp		250-350	X	X					X	
Balcony		250-350	X	X					X	
Stairs		250-350	X	X					X	
Driveway		250-350	X	X					X	
Other:										
Wooden floor (1)	80	50-70	X (1)	X			X	X		
Cold storage room (1)	15	10-15		X				X		
Storage heating	250	180-250	X	X						
Concrete drying		85-135		X						
Sports arena/hall		50-90		X						
Football field		50-90		X						
Greenhouse		70-90		X						
Frost protection:										
Room drains		30-50	X	X						X
On pipes < 2"		8-13		X						X
On pipes > 2"		10-14		X						X
Inside pipes < 2"		6-13								X (2)
Temperature maintenance:										
Warm water		9w/55 °C								X
High power										X

(1) Max 10 W/m

(2) For drinking water use DEFROST WATER

Cable output [W] = Gross area [m²] x Area load [W/m²]

For comfort heating in concrete constructions, we recommend the use of TXLP heating cable, single or twin conductor elements. To find the correct heating cable element, use the above calculation.

C-C [m] = Net area [m²] / Cable length [m]

Selection table, 10 W/m

The table below shows recommended products with TXLP/2R - 10 W/m and centre spacing for various room sizes and outputs

m ²	Load 40-60 W/m ²	cc-cm	Load 60-80 W/m ²	cc-cm	Load 80-100 W/m ²	cc-cm	Load 100-120 W/m ²	cc-cm
3			1 TXLP 230 W	13	1 TXLP 230 W	13	1 TXLP 380 W	08
4	1 TXLP 230 W	17	1 TXLP 230 W	17	1 TXLP 380 W	11	1 TXLP 380 W	13
5	1 TXLP 230 W	22	1 TXLP 380 W	13	1 TXLP 380 W	13	1 TXLP 530 W	09
6	1 TXLP 380 W	16	1 TXLP 380 W	16	1 TXLP 530 W	11	1 TXLP 760 W	08
7	1 TXLP 380 W	18	1 TXLP 530 W	13	1 TXLP 530 W	13	1 TXLP 760 W	09
8	1 TXLP 380 W	21	1 TXLP 530 W	15	1 TXLP 760 W	11	1 TXLP 940 W	08
9	1 TXLP 530 W	17	1 TXLP 760 W	12	1 TXLP 760 W	12	1 TXLP 1050 W	09
10	1 TXLP 530 W	19	1 TXLP 760 W	13	1 TXLP 940 W	11	1 TXLP 1050 W	09
11	1 TXLP 530 W	21	1 TXLP 760 W	14	1 TXLP 940 W	12	1 TXLP 1300 W	08
12	1 TXLP 530 W	22	1 TXLP 760 W	16	1 TXLP 1050 W	11	1 TXLP 1300 W	09
13	1 TXLP 760 W	17	1 TXLP 940 W	14	1 TXLP 1050 W	12	1 TXLP 1300 W	10
14	1 TXLP 760 W	18	1 TXLP 940 W	15	1 TXLP 1050 W	11	1 TXLP 1610 W	09
15	1 TXLP 760 W	20	1 TXLP 1050 W	14	1 TXLP 1300 W	12	1 TXLP 1610 W	09
16	1 TXLP 760 W	21	1 TXLP 1050 W	15	1 TXLP 1300 W	12	1 TXLP 1610 W	10
17	1 TXLP 940 W	18	1 TXLP 1300 W	13	1 TXLP 1610 W	11	2 TXLP 940 W	09
18	1 TXLP 940 W	19	1 TXLP 1300 W	14	1 TXLP 1610 W	11	2 TXLP 940 W	09
19	1 TXLP 940 W	20	1 TXLP 1300 W	15	1 TXLP 1610 W	12	2 TXLP 1050 W	10
20	1 TXLP 1050 W	19	1 TXLP 1300 W	15	1 TXLP 1610 W	12	2 TXLP 1050 W	09
21	1 TXLP 1050 W	20	1 TXLP 1610 W	13	2 TXLP 940 W	11	2 TXLP 1050 W	09
22	1 TXLP 1050 W	21	1 TXLP 1610 W	14	2 TXLP 1050 W	10	2 TXLP 1300 W	10
23	1 TXLP 1300 W	18	1 TXLP 1610 W	14	2 TXLP 1050 W	11	2 TXLP 1300 W	08
24	1 TXLP 1300 W	18	1 TXLP 1610 W	15	2 TXLP 1050 W	11	2 TXLP 1300 W	09
25	1 TXLP 1300 W	19	1 TXLP 1610 W	15	2 TXLP 1050 W	12	2 TXLP 1300 W	09
26	1 TXLP 1300 W	20	1 TXLP 1610 W	16	2 TXLP 1050 W	12	2 TXLP 1300 W	10
27	1 TXLP 1300 W	21	1 TXLP 1610 W	17	2 TXLP 1300 W	10	2 TXLP 1610 W	08

See page 47 for recommended output per room type.

Selection table, 17 W/m

The table below shows recommended products with TXLP/2R - 17 W/m and centre spacing for various room sizes and outputs

m ²	Load 60-80 W/m ²	cc-cm	Load 80-100 W/m ²	cc-cm	Load 100-120 W/m ²	cc-cm	Load 120-150 W/m ²	cc-cm
3			1 TXLP 300 W	17	1 TXLP 300 W	17	1 TXLP 400 W	12
4	1 TXLP 300 W	22	1 TXLP 400 W	17	1 TXLP 400 W	17	1 TXLP 500 W	13
5	1 TXLP 300 W	28	1 TXLP 400 W	21	1 TXLP 500 W	17	1 TXLP 600 W	14
6	1 TXLP 400 W	25	1 TXLP 500 W	20	1 TXLP 700 W	14	1 TXLP 840 W	12
7	1 TXLP 500 W	23	1 TXLP 600 W	20	1 TXLP 840 W	14	1 TXLP 1000 W	12
8	1 TXLP 500 W	27	1 TXLP 700 W	19	1 TXLP 840 W	16	1 TXLP 1000 W	13
9	1 TXLP 600 W	25	1 TXLP 840 W	18	1 TXLP 1000 W	15	1 TXLP 1250 W	12
10	1 TXLP 600 W	28	1 TXLP 840 W	20	1 TXLP 1000 W	17	1 TXLP 1250 W	13
11	1 TXLP 700 W	26	1 TXLP 840 W	22	1 TXLP 1250 W	15	1 TXLP 1370 W	13
12	1 TXLP 700 W	29	1 TXLP 1000 W	20	1 TXLP 1370 W	15	1 TXLP 1700 W	12
13	1 TXLP 840 W	26	1 TXLP 1000 W	22	1 TXLP 1370 W	16	1 TXLP 1700 W	13
14	1 TXLP 840 W	28	1 TXLP 1250 W	19	1 TXLP 1370 W	17	1 TXLP 1700 W	14
15	1 TXLP 1000 W	25	1 TXLP 1250 W	20	1 TXLP 1700 W	15	1 TXLP 2100 W	12
16	1 TXLP 1000 W	27	1 TXLP 1370 W	19	1 TXLP 1700 W	16	1 TXLP 2100 W	13
17	1 TXLP 1250 W	23	1 TXLP 1370 W	21	1 TXLP 1700 W	17	1 TXLP 2100 W	13
18	1 TXLP 1250 W	24	1 TXLP 1370 W	22	1 TXLP 2100 W	14	1 TXLP 2600 W	12
19	1 TXLP 1250 W	25	1 TXLP 1700 W	19	1 TXLP 2100 W	15	1 TXLP 2600 W	12
20	1 TXLP 1250 W	27	1 TXLP 1700 W	20	1 TXLP 2100 W	16	1 TXLP 2600 W	13
21	1 TXLP 1370 W	26	1 TXLP 1700 W	21	1 TXLP 2100 W	17	1 TXLP 2600 W	14
22	1 TXLP 1370 W	27	1 TXLP 1700 W	22	1 TXLP 2600 W	14	2 TXLP 1370 W	14
23	1 TXLP 1370 W	28	1 TXLP 2100 W	18	1 TXLP 2600 W	15	1 TXLP 3300 W	12
24	1 TXLP 1700 W	24	1 TXLP 2100 W	19	1 TXLP 2600 W	16	1 TXLP 3300 W	12
25	1 TXLP 1700 W	25	1 TXLP 2100 W	20	1 TXLP 2600 W	16	1 TXLP 3300 W	13
26	1 TXLP 1700 W	26	1 TXLP 2600 W	17	2 TXLP 1370 W	16	1 TXLP 3300 W	13
27	1 TXLP 1700 W	27	1 TXLP 2600 W	18	2 TXLP 1370 W	17	1 TXLP 3300 W	14
28	1 TXLP 2100 W	23	1 TXLP 2600 W	18	1 TXLP 3300 W	14	2 TXLP 1700 W	14
29	1 TXLP 2100 W	23	1 TXLP 2600 W	19	1 TXLP 3300 W	15	2 TXLP 2100 W	11
30	1 TXLP 2100 W	24	1 TXLP 2600 W	20	1 TXLP 3300 W	15	2 TXLP 2100 W	12

See page 47 for recommended output per room type.

LOAD DIAGRAM 120 VOLT

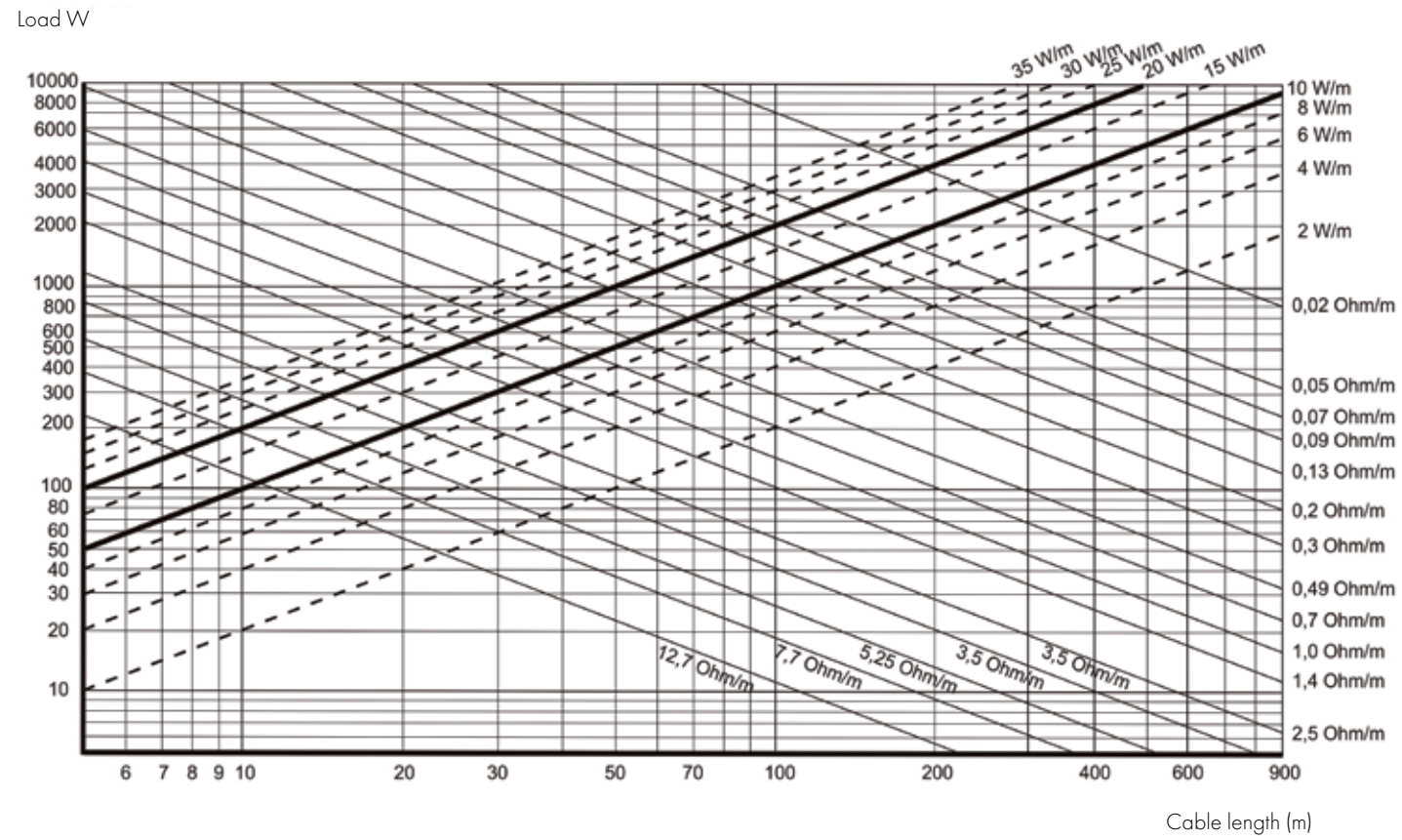

LOAD DIAGRAM 230 VOLT

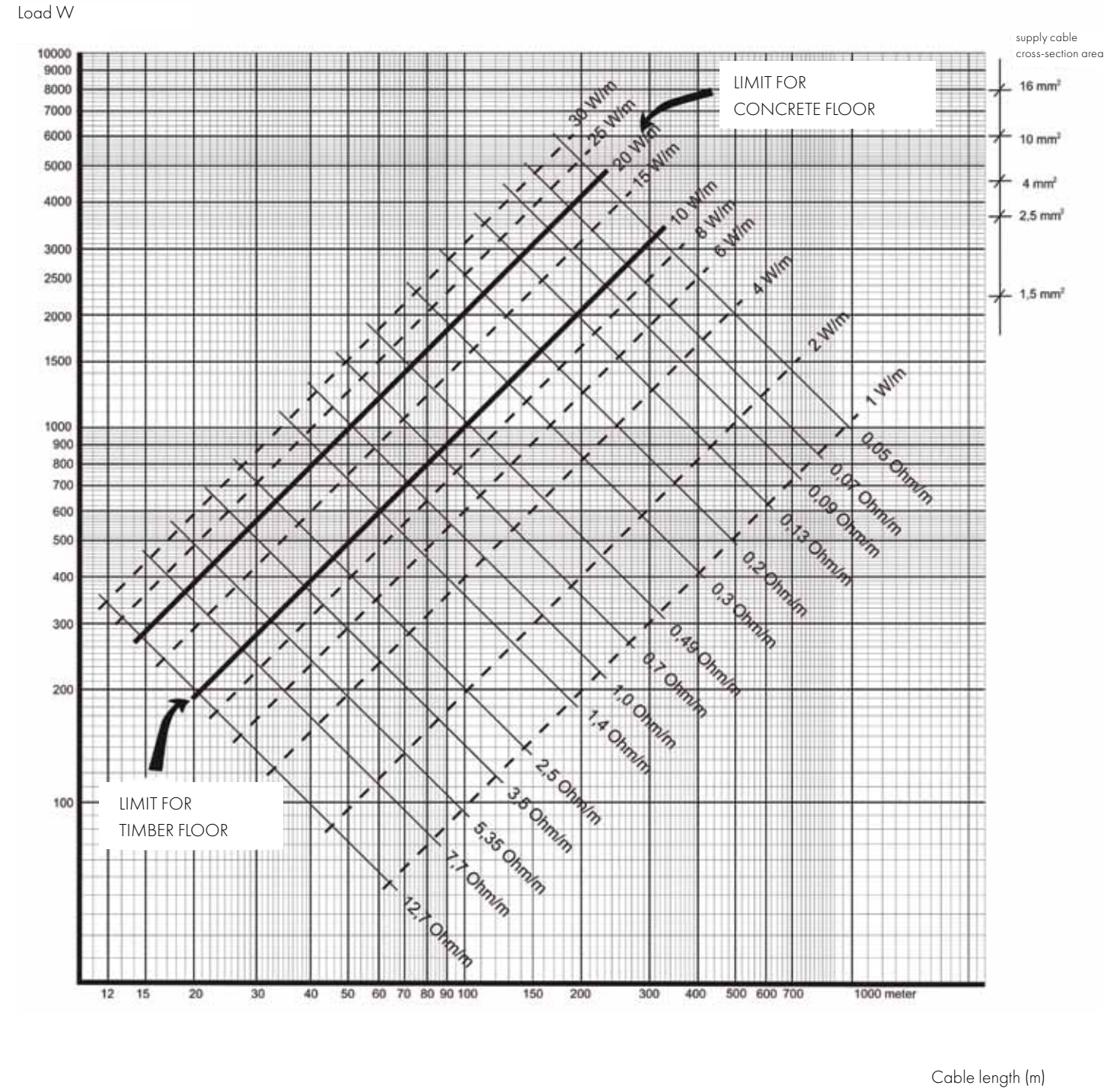

Nexans Norway AS is a leading supplier of power, telecommunications, installations and heating cables in Norway, and is among the world's leading manufacturers of offshore control cables and high-voltage submarine cables. The company's head office is in Oslo, and it has manufacturing plants at Rognan, Namsos, Langhus, Karmøy and Halden. The company has approx. 1,410 employees and are organised into three divisions: Market Line, Hybrid Underwater Cable and Submarine High Voltage.

More information on nexans.com/nheat



Website for Nexans heating cables
www.nexans.com/nheat

Nexans Norway AS,
Innspurten 9, Helsfyr,
P.O.Box 6450 Etterstad,
N-0605 Oslo, Norway

Phone: + 47 22 88 61 00,
Fax: + 47 22 88 61 01,
building.no@nexans.com

www.nexans.com/nheat